

Methanol—inhibitor or promoter of the formation of gas hydrates from deuterated ice?

SVILEN BOBEV* AND KIMBERLY T. TAIT

Manuel Lujan Jr. Neutron Scattering Center, LANSCE 12 MS H805, Los Alamos National Laboratory, Los Alamos, New Mexico 87545, U.S.A.

ABSTRACT

Kinetic studies are reported of the effect of methanol on the rate of formation of CO₂- and CH₄-hydrates by means of in situ time-of-flight neutron powder diffraction. The experiments were carried out at temperatures ranging from 200 to 250 K and pressures up to 7 MPa. The samples were prepared from mixtures of ground, deuterated ice and deuterated methanol (up to 20 vol%), which were transformed in situ into CO₂- or CH₄-hydrates by pressurizing the systems with the corresponding gas. The observed rates of formation of hydrates are orders of magnitude higher than the rate of formation from pure deuterated ice under the same pressure and temperature conditions. Glycols and alcohols, methanol in particular, are long known as thermodynamic inhibitors of hydrate formation. Our study indicates that methanol can also act as a kinetic promoter for the formation of gas hydrates. Preliminary data suggest that the kinetics also depend strongly on concentration and the isotopic composition.

INTRODUCTION

The crystal structures, thermodynamic models, and engineering applications of CO₂- and CH₄-hydrates have been extensively studied under equilibrium conditions (Sloan 1998a). Our knowledge of the kinetics of hydrate formation and decomposition on the other hand is rather limited. Studies of the formation and dissociation processes of hydrates are hindered by the complexity of the dynamic process and are often poorly reproducible. Typically, kinetic studies involve measurements of temperature and pressure changes of the gas and liquid phases to infer the properties and rate of structural changes of the hydrate phase. These experimental challenges, as recognized in some recent reviews on hydrate research (Sloan 1998b; Ripmeester and Ratcliffe 1998), are to directly measure the hydrate phase using techniques such as diffraction and NMR and Raman spectroscopy (Subramanian and Sloan 1999). In-depth information about generalized kinetics models will be crucial in assessing such issues as the feasibility of in situ production of methane from the methane hydrate deposits at the ocean floor (Herzog 1991; Nishikawa 1992; Saji 1992). Kinetic models are eagerly sought for the systems CO₂(l)/water/CH₄-hydrate aiming at the development of the technology to simultaneously extract methane from the ocean-floor reserves and replace it with carbon dioxide. Therefore, studies of nucleation, growth, and dissociation of different hydrates at various conditions have received increasing attention in recent years.

The use of powder diffraction techniques, powder neutron diffraction in particular, proves to be a powerful tool for probing these systems. To date, X-ray and neutron powder diffraction have been used for thermodynamic studies of carbon dioxide, propane, and methane hydrates, as well as for structural studies of methane and nitrogen hydrates (McMullan and Jeffery 1965; Mak and McMullan 1965; Davidson and Ripmeester 1984; Koh et al. 1996, 1997, 2002; Kuhs et al. 1996; Stern et al. 1996). In

particular, time-dependent neutron diffraction at a variety of temperatures and pressures has been effectively used to research the kinetics of gas hydrate formation and dissociation (Henning et al. 2000). These investigations were aimed at following the kinetics of formation and decomposition of carbon dioxide, methane, and other gas hydrates, using synchrotron X-ray radiation and neutron diffraction. Several publications on time-dependent kinetics of the hydrate formation and dissociation processes have already appeared in the literature (Henning et al. 2000; Halpern et al. 2001; Wang et al. 2002). More recently, the synthesis, structure, composition, and kinetic behavior of carbon dioxide hydrate were discussed in a comprehensive report based on X-ray and neutron diffraction, SEM, and residual gas analysis data (Circone et al. 2003; Staykova et al. 2003).

In the present study, we explore the effects of surfactants on the rate of formation of carbon dioxide and methane hydrate using neutron powder diffraction. This work provides direct observation of the in situ formation of carbon dioxide and methane hydrates from polycrystalline mixtures of deuterated ice and methanol, and evidence that methanol, in certain concentrations, accelerates tremendously the rate of the reaction from deuterated ice.

EXPERIMENTAL DETAILS

The experiments were carried out using the High Intensity Powder Diffractometer (HIPD) instruments at both the Manuel Lujan Jr. Neutron Scattering Center (LANSCE-12) at Los Alamos National Laboratory, and at the Intense Pulsed Neutron Source (IPNS) at Argonne National Laboratory. The experiments were conducted in a pressure sample cell, originally designed and fabricated at Argonne National Laboratory (Fig. 1), and later duplicated at Los Alamos National Laboratory. The cell is made of an aluminum alloy and is intended for use with pressures up to 70 MPa at room temperature or below. Details on the sample cell design and fabrication can be found elsewhere (Henning et al. 2000). Pressurized gas was introduced into the system through stainless-steel tubing that connects to standard gas cylinders with CO₂ (99.9%) and CH₄ (99.5%). The pressure was maintained at the desired level throughout the whole experiment by continual addition of gas. To monitor the pressure accurately, a digital pressure gauge was connected to the pressure cell.

Polycrystalline ice was prepared by freezing deuterated water (Aldrich or

* E-mail: sbobev@lanl.gov

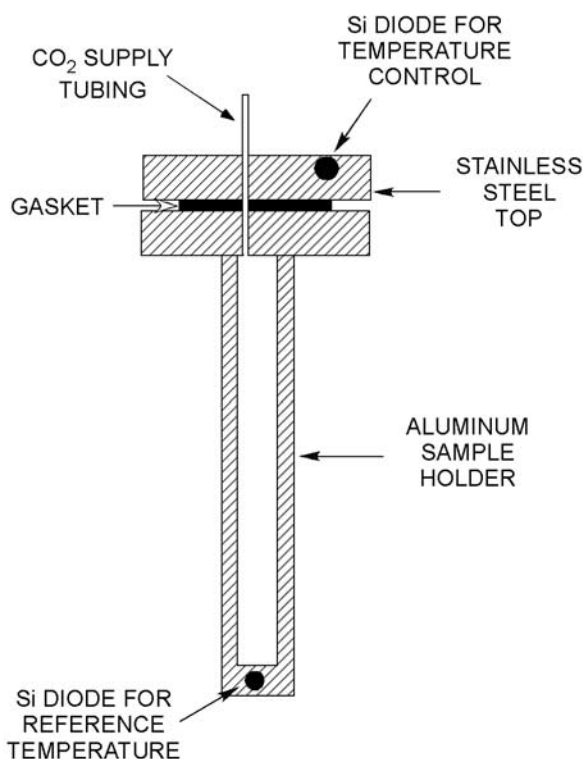

FIGURE 1. A schematic drawing of the aluminum pressure cell. The cell is approximately 76 mm long and has an inside diameter of 8 mm.

Cambridge-Isotope, 99.9%) and then crushing it with a mortar and pestle. The powder was then sieved through a stainless steel sieve (mesh -48) to obtain ice particles 300 μm and smaller. All these procedures were performed with caution and extreme care at around liquid nitrogen temperature to prevent the ice from melting. The powdered ice (kept submerged in liquid nitrogen to avoid frost deposits) was then inserted into the aluminum pressure cell, which had already been cooled to 77 K. The cell was subsequently closed (while keeping it in a small dewar flask filled with liquid nitrogen), and quickly mounted on the cold stage of a Displex closed-cycle helium refrigerator. Two silicon diodes for temperature control and for reference (top and bottom of the cell as shown in Fig. 1) were attached and the assembly was then put into the sample chamber of the neutron diffractometer. As previously mentioned, the pressure cell was kept in liquid nitrogen as much as possible to prevent the ice from melting and to discourage condensation buildup on the outside of the cell. This is a concern because the incoherent scattering of the hydrogen would lead to a higher background in the diffraction data.

The same general procedure was followed for the preparation of several frozen water-alcohol mixtures with different concentrations, ranging from 20% by volume to 1% by volume. We started our studies with the most alcohol-rich system ($\text{CD}_3\text{OD}:\text{D}_2\text{O} = 1:4$), again by freezing it in liquid nitrogen. The frozen mixture was then quickly ground, sieved, and transferred into the aluminum cell, which was subsequently closed and attached to the cold finger of the Displex refrigerator (see above). Once the temperature was stabilized at ca. 200 K, a neutron diffraction pattern of the frozen, polycrystalline mixture was obtained to check for the presence of hexagonal ice and to make sure that it had not melted. Limited beam time precluded the completion of the whole series of experiments; those still to be made will be discussed in another paper.

Monitoring of the reaction pathway began with pressurizing the sample cell with CO_2 or CH_4 gas (maximum pressures up to 7 MPa) at temperatures of 250 K or below. Before the gas was introduced into the system, the cell was purged with helium and the gas supply lines were bled to get rid of unwanted air. The sample was allowed to stabilize a few degrees below the desired temperature. The gas was then introduced rapidly, and usually a temperature increase of $\sim 5\text{--}7$ K was observed as indicated from the temperature reading difference between the two thermocouples (Fig. 1). The "fluctuation" in the temperature is most likely due to the pressurizing gas being at a higher temperature, along with the heat deposited

in the system from the rapid formation of hydrate, which is an exothermic reaction (Henning 2000). The temperature stabilized within a few minutes.

At the same time as the gas was being introduced, the shutters were open and time-of-flight powder diffraction data were obtained virtually in real time by creating a sequence of data collection runs, each with a duration of approximately 15 minutes. The high neutron flux from both HIPD instruments allowed for fast data collection times. The spallation neutron source at LANSCE is pulsed at 20 Hz and ~ 100 μA power, while the IPNS is pulsed at 30 Hz and ~ 15 μA power. The time-of-flight neutron powder diffraction data were obtained by using the 90° data bank(s) on both systems. For comparison, the HIPD instrument at LANSCE-12 has a primary flight path (moderator-to-sample) of 9 m and a secondary flight path (sample-to-detectors) of 1 m. For the HIPD instrument at the IPNS, the sample position is located 5.5 m from the source and the sample-to-detectors distance is 1 m. Data analysis was done using the GSAS software package (Larson and Von Dreele 1994). The structural model employed in the refinements was adopted from an earlier in situ neutron diffraction study of CO_2 hydrates (Henning et al. 2000).

RESULTS AND DISCUSSION

In nature or in laboratory experiments, gas hydrates typically form around 273 K (0 °C) and under moderate pressure (≤ 70 MPa). When the pressure is released, or the temperature is increased, the hydrates decompose. The rate of decomposition varies with temperature and the type of guest molecule in the structure. In general, methane hydrates in particular decompose quickly and therefore have to be prepared in situ to prevent decomposition during transfer from one sample environment to another. In situ data may provide information at the atomic scale on the stability of the hydrate phases, as well as for the formation/decomposition kinetics. Neutron diffraction is a powerful tool for following structural changes that occur under these conditions. Neutrons are particularly useful for analyzing light elements such as hydrogen and O, since their penetrating power and lack of intensity fall-off with scattering angle allow for obtaining precise structural information on atomic positions, interatomic distances, and atomic displacement parameters under a variety of experimental conditions. Moreover, these experiments can be accomplished with much higher precision than can be done with X-ray diffraction methods.

Earlier experiments that utilized this technique have already demonstrated that one could successfully prepare and analyze gas hydrates in situ (Henning et al. 2000; Halpern et al. 2001; Wang et al. 2002). We are now extending these studies toward the kinetics of formation of CO_2 hydrate from systems containing methanol or electrolytes, with a long-term goal to prepare other types of gas hydrates, especially methane hydrate.

In abbreviated terms, the in situ monitoring of the structural transformations begins with collection a neutron diffraction pattern of the frozen ice or polycrystalline mixture of ice and alcohol stabilized at 200 K. This is done before the sample is pressurized to confirm that the ice (or the frozen mixture) has not melted, and to see if a clean powder pattern can be observed. Hexagonal ice is clearly present in Figure 2a, along with peaks from the aluminum sample cell. The positions of aluminum peaks occur at d -spacings of 2.34 Å and lower. After confirming that the ice did not melt during the setup phase, the cell was allowed to equilibrate at the desired starting temperature and then pressurized with CO_2 or CH_4 (pressures up to 7 MPa). Collection of time-resolved data (15–30 minutes) showed that peaks corresponding to type-I hydrate appear almost immediately (Fig. 2b). The reaction between the gas and the ice continues and at the end nearly 100% conversion can be achieved at certain conditions (Fig. 2c). Similar

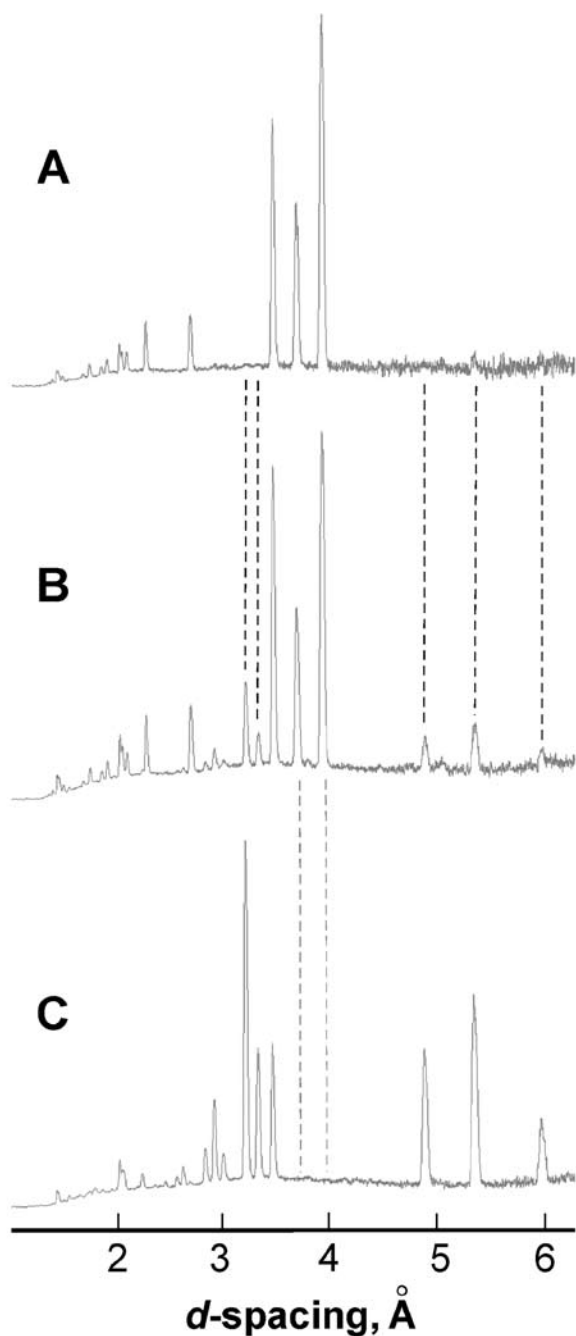

FIGURE 2. Virtually real time monitoring (15 minutes per histogram) of the kinetics of formation of CO_2 hydrate from polycrystalline ice by in situ neutron powder diffraction. (a) Beginning of the reaction—neutron powder diffraction pattern of the D_2O ice (hexagonal structure, space group $P6_3/mmc$) at 200 K with no pressure; (b) Reaction in progress, system pressurized with either CO_2 or CH_4 —neutron powder diffraction pattern of the mixture of hexagonal D_2O ice and type-I hydrate. This pattern can be viewed as a superposition of patterns (a) and (c), with relative intensities corresponding to the mole fractions of the two phases, respectively. (c) End of the reaction, i.e., all D_2O ice converted in situ to hydrate—neutron powder diffraction pattern type-I hydrate (primitive cubic structure, space group $Pm\bar{3}n$) at 200 K and 7 MPa He. The y-axis (not shown) represents the intensity in arbitrary units.

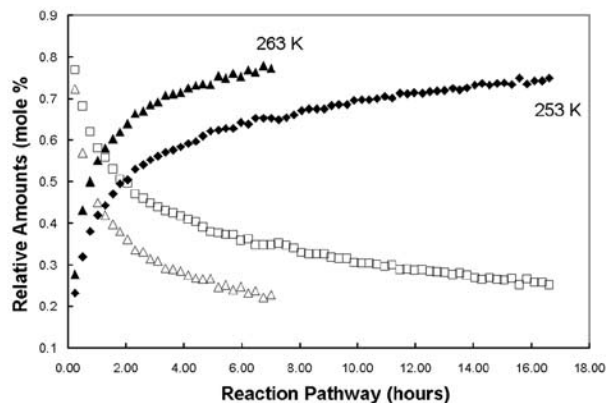

FIGURE 3. Conversion of deuterated ice to carbon dioxide hydrate at 6 MPa at temperatures of 263 and 253 K (filled symbols represent the fraction of hydrate, open symbols stand for the fraction of ice). Each data point represents the mole fraction as refined from a 15 min histogram. Data from Henning et al. (2000), courtesy of A. J. Schultz.

studies conducted at different temperatures have provided useful kinetic information on hydrate formation (Henning et al. 2000; Halpern et al. 2001; Wang et al. 2002).

The short data collection times and relatively low resolution of the HIPD instruments did not allow for a full Rietveld analysis of each data set (Larson and Von Dreele 1994). The lattice parameters of the three phases observed in the diffraction patterns, hydrate, ice, and aluminum were refined in the initial stages but then were fixed since the temperature and pressure of the sample did not change during the data collection. The atomic positions and thermal parameters, as determined in separate experiments for each temperature, were not allowed to vary during the refinements. Besides the six background parameters, only the histogram scale factor, an absorption coefficient, and the phase fractions were allowed to refine. The weight fractions were extracted from each refinement, adjusted for the gain of CO_2 in the solid phase, and the mole fractions of hydrate were calculated (Fig. 3).

As can be seen in Figure 3, the rate of formation significantly depends on the temperature (Henning et al. 2000; Halpern et al. 2001; Wang et al. 2002). Also, these studies of the conversion of ice to hydrate suggest a two-stage process—initial reaction of CO_2 (or another hydrate-forming gas) with the so-called quasi-liquid layer (QLL), followed by diffusion of the gas molecules through the layers of hydrate covering the ice particles (Henning et al. 2000; Halpern et al. 2001; Wang et al. 2002; Takeya et al. 2000). Importantly, direct observation of CO_2 hydrate formation on the surface of ice grains has also been reported by others (Hwang 1990; Staykova et al. 2003; Stern et al. 1998a, 1998b), which supports the hypothesis that after diffusion through the hydrate layer, the gas molecules react with internal water in a QLL or “pre-melting” layer, rather than with ice molecules. This opens up a large area of possible kinetic studies of the CO_2 and other gas hydrate systems.

The next step was to complete similar in situ experiments, when instead of pure D_2O ice, a frozen mixture of D_2O with deuterated alcohols, glycols, electrolytes, etc. was reacted with CO_2 gas and the rate of the conversion to a CO_2 hydrate was de-

terminated in the same way as before. The accessible experimental data on alcohols and glycols are scarce and large gaps exist in the study of these systems. Furthermore, the latter are known as “thermodynamic inhibitors” of hydrate formation since addition of these compounds in certain concentrations moves the conditions required for hydrate formation toward lower temperatures and higher pressures (Sloan 1998a; Majumdar et al. 2000; Mei et al. 1996 and references therein; Koh et al. 2002). The cases where thermodynamic inhibition is claimed are all in V-L-H systems (vapor-liquid-hydrate), not in the V-I-H (vapor-ice-hydrate) systems that are the focus of our study. In fact, the petroleum and gas industry rely heavily on the technology of these “inhibitors” to prevent gas hydrate formation in pipelines. Although alcohols and glycols have been used for many years, little is known about the mechanisms of their inhibition in these V-I-H systems.

With those ideas and background in mind, we undertook an in situ neutron diffraction experiment, starting with the simplest possible alcohol-methanol. Because hydrogen has a large incoherent scattering cross-section, while its heavier isotope deuterium has a large coherent scattering cross-section, both the water and methanol we used were fully deuterated. The diffraction pattern taken at 200 K, as plotted on Figure 4a, shows only peaks corresponding to the structure of hexagonal ice. Indeed, this is what one should see at these P - T conditions, since the freezing point depression for the system in consideration (20% methanol by volume) is approximately 15°. Methanol on the other hand freezes at ~170 K, i.e., no peaks from solid methanol or other phases, excluding the Al peaks from the cell, should be observed in the powder pattern. Some controversy regarding the possibility of methanol forming hydrate (just as THF or others do) has arisen in recent years. This stemmed from previous work on the water-methanol system, based on molecular spectroscopy and X-ray diffraction. Supposedly at high enough methanol concentrations and sufficiently low temperatures, even without pressure, water and methanol could form type-II hydrate with the methanol molecules occupying the large cages (Blake et al. 1991). Based on molecular dynamic simulations, others have argued ever since that conventional hydrate structures containing methanol as a guest species are inherently unstable at any temperature (Koga et al. 1994), a model which agrees with other experiments that show no evidence for the existence of any type of water-methanol hydrate (Murthy 1999).

Claims that methanol and water form a monohydrate at liquid nitrogen temperature, and thus are unlikely to form any type of clathrate also exist, in apparent contradiction with FTIR spectra showing mixed methanol hydrates (Williams and Devlin 1997). Our in situ neutron diffraction patterns at 200 K unequivocally establish that only hexagonal ice is present in the system at these conditions. This observation might also support the hypothesis that methanol and water form some amorphous co-deposits, with the aim of a help gas at appropriate P - T conditions (Blake et al. 1991).

Figure 4b illustrates the changes in the system in question only 20 minutes after the cell was pressurized with CO₂ gas at 1.7 MPa. The temperature rose quickly to approximately 250 K and the whole reaction essentially took place within a few minutes at that temperature. As can be seen from the graph, nearly all the ice peaks have disappeared and only the tips of the three

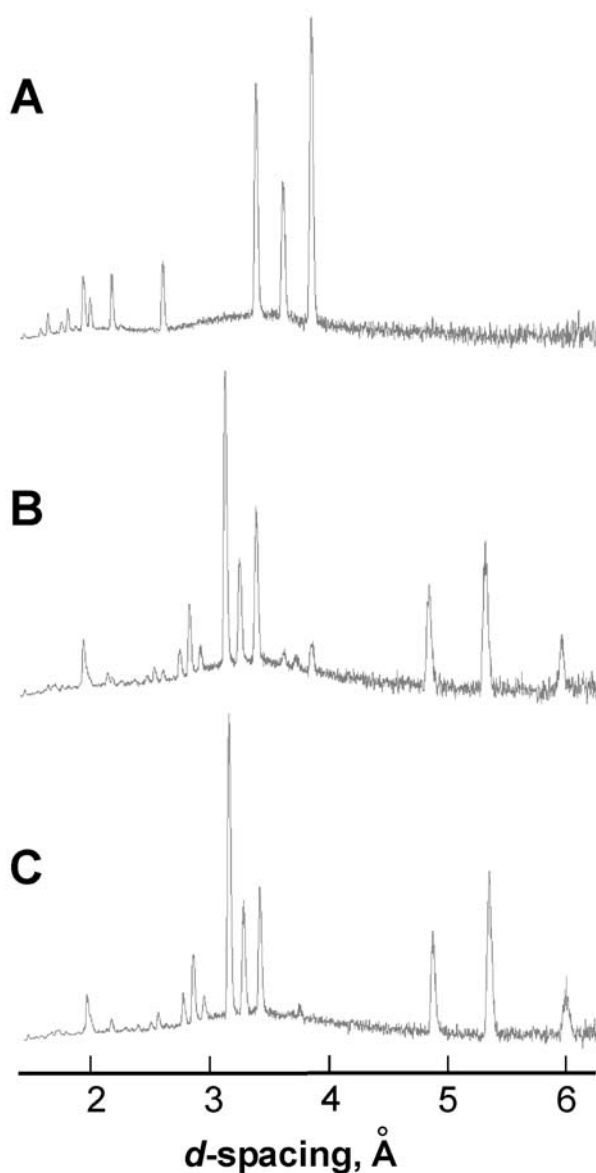

FIGURE 4. In situ neutron powder diffraction patterns of a frozen D₂O + CD₃OD mixture at 220 K with no pressure (a); and the corresponding patterns 20 minutes (b) and 40 minutes (c) after the system was pressurized with CO₂ at 250 K and 1.7 MPa. Due to the rapid conversion rates, the fractions of ice and hydrate could not be accurately refined. The y-axis (not shown) represents the intensity in arbitrary units.

strongest (at around d -spacings of 3.5 Å) peaks are still visible. After another 20 minutes, virtually only peaks from type-I CO₂ hydrate are present (Fig. 4c). Unfortunately, refining these data and extracting the mole fractions of ice and hydrate from both histograms is not possible because of the rapid conversion rates. Nevertheless, it gives a relative idea of how much faster the reaction is for the CD₃OD:D₂O mixture compared to the rate of the reaction of CO₂ gas with pure D₂O ice at comparable temperatures (253 and 263 K) and even at much higher pressure (Fig. 3). Evidently, it takes more than 20 hours for an 80 mol% conversion in the pure ice-carbon dioxide system, while a similar outcome is observed in the CD₃OD/D₂O-carbon dioxide system

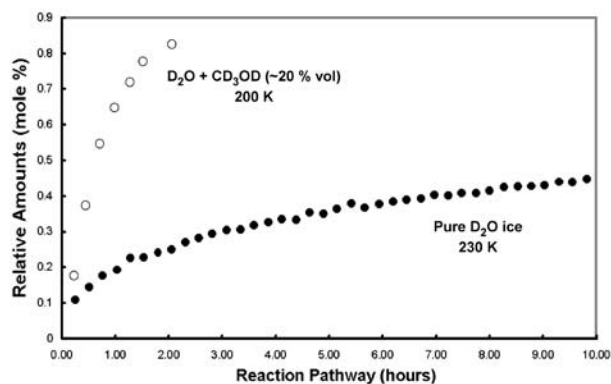

FIGURE 5. Comparison between the rate of conversion of deuterated ice to carbon dioxide hydrate at 6 MPa and at 230 K and the rate of conversion of a mixture of deuterated ice and deuterated methanol to carbon dioxide hydrate at the same pressure and at a temperature of 200 K.

within 20 minutes.

To slow down the reaction for the sake of obtaining “time-resolved” data, a new set of data was collected for the same system ($\text{CD}_3\text{OD}:\text{D}_2\text{O} = 1:4$), but at lower temperature, 200 K. Since the rate of formation of CO_2 hydrate from pure D_2O ice at 230 K and at 6 MPa has previously been reported (Henning et al. 2000) this low temperature experiment was also done at 6 MPa. This allowed for direct comparison between the results of these two experiments; Figure 5 shows the conversion rates. The graph clearly demonstrates the dramatic effect of methanol on the rate of the formation—an increase of more than a factor of 3, not taking into account the difference in temperatures. Although the mole fractions were extracted from the refined data, their standard uncertainties are large and this comparison is qualitative. The “error-bars” (not shown) are on the high side because, even at 200 K, the reaction takes place rapidly and the data from each of these seven 20 minute runs illustrate the average change. From that point of view, methanol, the long believed “thermodynamic inhibitor”, which is of immediate relevance to many branches of chemical technology, turns out to be an effective “kinetic promoter” of hydrate formation from polycrystalline ice.

Studies of thermodynamic and kinetic properties of various alcohol-water mixtures in the liquid phase are also receiving increasing attention. This interest has arisen from the proposed micelle-like structures of these systems, which are of biological significance (Koga et al. 1990; Roux et al. 1978; Mittal 1977; Myers 1988). However, information on the kinetic behavior of aqueous solutions of alcohols is scarce and incomplete, mostly due to the long crystallization times.

The limited availability of neutron beam time, along with technical difficulties precluded more detailed temperature-, concentration-, and/or isotope-dependent studies. Therefore, no general kinetic model can be proposed at this point. Our preliminary results suggest strong isotope and concentration effects, although these experiments suffer from relatively poor reproducibility. After all, as summarized in Sloan’s section on kinetic inhibition (Sloan 1998a), the literature indicates that kinetic studies often appear to be system dependent. Hence, all these controversial and poorly reproducible results might be due to differences in

the preparation techniques, small changes in the experimental conditions, and/or isotope effects (H vs. D). In our case, however, this often speculated possibility for “system dependence” as a possible reason can be ruled out. All experiments reported herein were carried out more than once at different neutron sources and using different experimental setups. A more likely reason for the “system dependence” seems to be the lowered melting point of the $\text{CD}_3\text{OD}/\text{D}_2\text{O}$ mixture, which may cause melting (or rather softening) of the cell contents, especially the top part, during the processes of sealing and mounting on the cold finger of the Displex-refrigerator. Upon the subsequent active cooling (note that the top of the cell is directly attached to the cold finger), that part may freeze in the form of a “plug” and thus prevent the hydrate-forming gas from distributing freely within the volume of the whole cell. Subsequently, the substantial heat of hydrate formation, released within the first few minutes, causes large fluctuations in the temperature, and may contribute to unwanted melting of ice particles.

The direct comparison of the rates of formation from systems with partially and fully deuterated methanol seems to indicate that at similar concentrations, the partially deuterated reagent does not have the same influence over the kinetics as the fully deuterated one. Hydrogen-bonding effects certainly play an important role and substantial bonding of the methanol molecule might occur with the “cage wall,” presumably to the O atoms so that the guest species assumes a particular orientation within the hydrate cage. Williams and Devlin (1997) drew similar conclusions from their FTIR experiments of the formation of double hydrates of methanol and ether and methanol and THF at cryogenic temperatures. Their work also reveals indications for substantial O-H and O-D interactions within the cages, much stronger than presumed by the van der Waals model for hydrate formation.

Deuterium, as discussed already, has a large coherent scattering cross-section while hydrogen absorbs strongly and scatters incoherently and hence is less suitable for neutron diffraction experiments. The necessity to work with deuterium-enriched samples is demonstrated in our first round of experiments on the effect of methanol on the kinetics of formation of methane hydrate at similar P - T conditions. These tested the feasibility of similar kinetic studies, when methane is used in place of carbon dioxide. Since commercial deuterated methane is expensive, regular and hydrogenous methane was used. These preliminary results, aside from the slightly higher background, as shown in Figure 6, are encouraging and demonstrate again a high conversion rate, even at a temperature of 200 K and a pressure of 1.7 MPa. Previous in situ neutron diffraction experiments using regular CH_4 and pure D_2O ice revealed that the formation of methane hydrate from deuterated ice obeys the same general kinetic behavior, although at significantly slower rates (Wang et al. 2002). That study reported 70% conversion after 24 hours at a CH_4 pressure of 7 MPa, and at 273 K, while our experiment with the frozen $\text{CD}_3\text{OD}/\text{D}_2\text{O}$ mixture (1:4 by volume) realizes nearly the same conversion efficiency in only 90 minutes at a temperature of 200 K and a pressure of 1.7 MPa!

In contrast to the preceding experiment with regular CH_4 and pure D_2O ice (Staykova et al. 2003; Wang et al. 2002), our data was hampered by high backgrounds, so that the subsequent Rietveld refinements are not of good quality. Sample decompo-

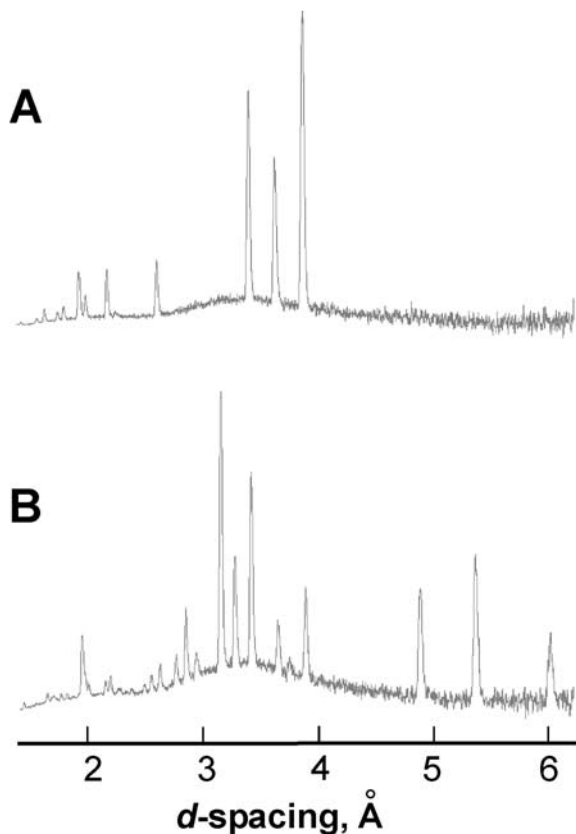

FIGURE 6. In situ neutron powder diffraction patterns of a frozen D_2O + CD_3OD mixture at 200 K with no pressure (a); and the corresponding pattern 90 minutes (b) after the system was pressurized with CH_4 at 200 K and 1.7 MPa. The higher background is due to the presence of H (large incoherent scattering cross-section). The y-axis (not shown) represents the intensity in arbitrary units.

sition also seems to be rapid and all hydrate peaks completely disappear within minutes.

Although the effect of methanol on the kinetics of formation and decomposition of CO_2 and CH_4 hydrates is clearly observed, many questions still remain to be answered, of which the most important one is: where are the methanol molecule(s) in the hydrate structure? It is unlikely that the enhanced kinetics are due to localized melting during the exothermic reactions (e.g., locally elevated temperatures and reaction of gas with liquid water-methanol/ice mixture/slurry instead of with solid ice), yet the possibility for that and for the presence of liquid methanol cannot be completely excluded. One might also speculate that if the ice and methanol formed some sort of composite crystalline or amorphous phase at liquid nitrogen temperatures, then raising the temperature to a point where the methanol melts might leave behind a highly porous residual ice structure. In this case, the apparent increase in kinetics could simply be due to a much higher surface area of the ice sample (i.e., the rate depends on the texture of the ice, which in turn is affected by how it was made and handled). Other mechanisms for the promoted kinetics might include mass transfer of guests to the growing hydrate or

heat transfer away from the growing crystals. Thus, the apparent increase in the conversion rate of the frozen methanol-water mixture could be due to an increased heat capacity in the system. In this scenario, addition of methanol increases the heat capacity of the overall system, and as a consequence, the heat of formation is deposited into the methanol-rich phase. If the global rate were governed by heat removal, then there would be an apparent increase in the rate since the heat of formation need not be transferred to the system boundary for hydrates to form. Along these lines, if liquid methanol is in contact with the vessel walls, then the heat transfer coefficient could be increased leading to a higher heat flux (and more rapid apparent kinetics). We cannot eliminate this possibility, because we do not have strong evidence that methanol is frozen at the P - T conditions of the experiment. However, the heat capacities for ice and methanol are not sufficiently different to explain why simply absorbing the hydrate heat of formation has such a strong promoting effect on the methanol.

Another explanation for these rapid rates of formation when methanol is present in the system is to assume methanol is a “help gas”. Some previously mentioned FTIR experiments indicate a substantial bonding of the methanol molecule with the “cage walls” (Williams and Devlin 1997). These hydrogen bonds, presumably to the O atoms that make up the hydrate frameworks might constrain a particular orientation of the methanol molecule within the hydrate cage. These interactions within the cages will be much stronger than the typical van der Waals bonding in simple hydrates and may contribute to the spectacular magnitude of the promoting effect.

ACKNOWLEDGMENTS

S.B. gratefully acknowledges the Director’s Postdoctoral Fellowship at Los Alamos National Laboratory for the financial support. We are also indebted to L.L. Daemen (LANSCE-12) for his help in the development and testing of the new pressure cell and for some useful suggestions and ideas in the early stages of the work. Our thanks also go to A.J. Schultz and J.A. Cowan (IPNS) for their assistance with the data collection, and for useful discussions.

REFERENCES CITED

- Blake, D., Allamandola, L., Sandford, S., Hudgins, D., and Freund, F. (1991) Clathrate hydrate formation in amorphous cometary ice analogs in vacuo. *Science*, 254, 548–551.
- Circone, S., Stern, L.A., Kirby, S.H., Durham, W.B., Chakoumakos, B.C., Rawn, C.J., Rondinone, A.J., and Ishii, Y. (2003) CO_2 hydrate: synthesis, composition, dissociation behavior, and a comparison to structure I CH_4 hydrate. *Journal of Physical Chemistry B*, 107, 5529–5539.
- Davidson, D.W. and Ripmeester, J.A. (1984) NMR, NQR, and dielectric properties of clathrates. In J.E.D. Davies and D.D. MacNichol, Eds., *Inclusion Compounds*, Vol. 3, Chapter 3. Academic Press, New York.
- Halpern, Y., Thieu, V., Henning, R.W., Wang, X.P., and Schultz, A.J. (2001) Time-resolved in situ neutron diffraction studies of gas hydrate: Transformation of structure II (sII) to structure I (sI). *Journal of the American Chemical Society*, 123, 12826–12831.
- Henning, R.W., Schultz, A.J., Thieu, V., and Halpern, Y. (2000) Neutron diffraction studies of CO_2 clathrate hydrate: Formation from deuterated ice. *Journal of Physical Chemistry A*, 104, 5066–5071.
- Herzog, H., Golomb, D., and Zemba, S. (1991) Feasibility, modeling and economics of sequestering power-plant CO_2 emissions in the deep ocean. *Environmental Progress*, 10, 64–74.
- Hwang, M.J., Wright, D.A., Kapur, A., and Holder, G.D. (1990) An experimental study of crystallization and crystal-growth of methane hydrates from melting ice. *Journal of Inclusion Phenomena and Molecular Recognition in Chemistry*, 8, 103–116.
- Koga, Y., Siu, W.Y.W., and Wong, T.Y.H. (1990) Transition of short-range to medium-range order in aqueous solution of 2-butoxyethanol. *Journal of Physical Chemistry*, 94, 3879–3881.
- Koga, K., Tanaka, H., and Nakanishi, K. (1994) Stability of polar guest-encaging

- clathrate hydrates. *Journal of Physical Chemistry*, 101, 3127–3134.
- Koh, C.A., Savidge, J.L., and Tang, C.C. (1996) Time-resolved in-situ experiments on the crystallization of natural gas hydrates. *Journal of Physical Chemistry A*, 100, 6412–6414.
- Koh, C.A., Soper, A.K., Westacott, R.E., Wisbey, R.P., Wu, X., Zhang, W., and Savidge, J.L. (1997) Neutron diffraction measurements of the nucleation and growth mechanisms of methane hydrate. 213th National Meeting of the American Chemical Society, San Francisco. American Chemical Society, Washington, D.C.
- Koh, C.A., Westcott, R.E., Zhang, W., Hirachand, K., Creek, J.L., and Soper, A.K. (2002) Mechanisms of gas hydrate formation and inhibition. *Fluid Phase Equilibria*, 194, 143–151.
- Kuhs, W.F., Chazallon, B., Radaelli, P., Pauer, F., and Kipfstuhl, J. (1996) Raman spectroscopic and neutron diffraction studies on natural and synthetic clathrates of air and nitrogen. Proceedings of the 2nd International Conference on Natural Gas Hydrates, Toulouse, France. Institute National Polytechnique, Toulouse, France.
- Larson, A.C. and Von Dreele, R.B. (1994) GSAS-General Structure Analysis System. LAUR 86-748, Los Alamos National Laboratory, New Mexico.
- Majumdar, A., Mahmoodaghdan, E., and Bishnoi, P.R. (2000) Equilibrium hydrate formation conditions for hydrogen sulfide, carbon dioxide, and ethane in aqueous solutions of ethylene glycol and sodium chloride. *Journal of Chemical and Engineering Data*, 45, 20–22.
- Mak, T.C. and McMullan, R.K. (1965) Polyhedral clathrate hydrates X. Structure of double hydrate of tetrahydrofuran and hydrogen sulfide. *Journal of Chemical Physics*, 42, 2732–2740.
- McMullan, R.K. and Jeffrey, G.A. (1965) Polyhedral clathrate hydrates 0.9 structure of ethylene oxide hydrate. *Journal of Chemical Physics*, 42, 2725–2733.
- Mei, D.-H., Liao, J., Yang, J.-T., and Guo, T.-M. (1996) Experimental and modeling studies on the hydrate formation of a methane plus nitrogen gas mixture in the presence of aqueous electrolyte solutions. *Industrial and Engineering Chemistry Research*, 35, 4342–4347.
- Mittal, K.L. (1977) *Micellization, Solubilization and Microemulsions*, Vol. 1. Plenum Press, New York.
- Murthy, S.S.N. (1999) Detailed study of ice clathrate relaxation: Evidence for the existence of clathrate structures in some water-alcohol mixtures. *Journal of Physical Chemistry A*, 103, 7927–7937.
- Myers, D. (1988) *Surfactant Science and Technology*. VCM Publishers, New York.
- Nishikawa, N., Morishita, M., Uchiyama, M., Yamaguchi, F., Ohtsubo, K., Kimuro, H., and Hiraoka, R. (1992) CO₂ clathrate formation and its properties in the simulated deep ocean. *Energy Conversion and Management*, 33, 651–657.
- Ripmeester, J.A. and Ratcliffe, C.I. (1998) The diverse nature of dodecahedral cages in clathrate hydrates as revealed by Xe-129 and C-13 NMR spectroscopy: CO₂ as a small-cage guest. *Energy and Fuels*, 12, 197–200.
- Roux, G., Perron, G., and Desnoyers, J.E. (1978) Heat-capacity evidence for pseudo-phase transitions in aqueous organic binary-systems. *Journal of Physical Chemistry*, 82, 966.
- Saji, A., Yoshida, H., Sakai, M., Tani, T., Kamata, T., and Kitamura, H. (1992) Fixation of carbon-dioxide by clathrate-hydrate. *Energy Conversion and Management*, 33, 643–649.
- Sloan, E.D. (1998a) *Clathrate Hydrates of Natural Gases*, 2nd ed. Marcel Dekker, New York, and the references therein.
- — — (1998b) Gas hydrates: Review of physical/chemical properties. *Energy and Fuels*, 12, 191–196.
- Staykova, D.K., Kuhs, W.F., Salamatin, A.N., and Hansen, T. (2003) Formation of porous gas hydrates from ice powders: diffraction experiments and multistage model. *Journal of Physical Chemistry B*, 107, 10299–10311.
- Stern, L.A., Kirby, S.H., and Durham, W.B. (1996) Peculiarities of methane clathrate hydrate formation and solid-state deformation, including possible superheating of water ice. *Science*, 273, 1843–1848.
- Stern, L.A., Hogenboom, D.L., Durham, W.B., Kirby, S.H., and Chou, I.-M. (1998a) Optical cell evidence for superheated ice under gas-hydrate-forming conditions. *Journal of Physical Chemistry B*, 102, 2627–2632.
- Stern, L.A., Kirby, S.H., and Durham, W.B. (1998b) Polycrystalline methane hydrate: synthesis from superheated ice, and low-temperature mechanical properties. *Energy and Fuels*, 12, 201–211.
- Subramanian, S. and Sloan, E.D. (1999) Molecular measurements of methane hydrate formation. *Fluid Phase Equilibria*, 158–160, 813–820.
- Takeya, S., Hondoh, T., and Uchida, T. (2000) *In situ* observation of CO₂ hydrate by X-ray diffraction. In G. Holder and P. Bishnoi, Eds., *Gas Hydrates: Challenges for the Future*, p. 973–982. New York Academy of Sciences, New York.
- Wang, X.P., Schultz, A.J., and Halpern, Y. (2002) Kinetics of methane hydrate formation from polycrystalline deuterated ice. *Journal of Physical Chemistry A*, 106, 7304–7309.
- Williams, K.D. and Devlin, J.P. (1997) Formation and spectra of clathrate hydrates of methanol and methanol-ether mixtures. *Journal of Molecular Structure*, 416, 277–286.

MANUSCRIPT RECEIVED SEPTEMBER 25, 2003

MANUSCRIPT ACCEPTED FEBRUARY 4, 2004

MANUSCRIPT HANDLED BY BRYAN CHAKOUMAKOS