



True triaxial loading apparatus and its application to coal outburst prediction

A.D. Alexeev^{a,*}, V.N. Revva^a, N.A. Alyshev^b, D.M. Zhitlyonok^b

^a*Institute for Physics of Mining Processes, Donetsk, Ukraine*

^b*Ministry of Coal Industry of Ukraine, Donetsk, Ukraine*

Received 19 April 2003; received in revised form 19 September 2003; accepted 23 September 2003

Available online 12 March 2004

Abstract

Two generations of true triaxial loading (TTAL) apparatuses are presented. First generation apparatuses were intended primarily for true stress state imitation in rock or mineral specimens. Advanced second-generation installations are designed to provide precise measurements in any stress and simulation of rock outburst at sudden relief of one sample face. Both TTAL apparatuses can apply pressure up to 250 MPa corresponding to earth depth about 10,000 m independently along each of three axes. Experimental results are given on effect of absorbed water on ultimate state in coal as well as adsorbed methane influence on simulated coal outbursts.

© 2004 Published by Elsevier B.V.

Keywords: True triaxial loading; Rock mass; Stress state; Simulation; Coal; Outbursts

1. Introduction

During last several decades, a system of parameters describing the physical and mechanical properties of rocks was significantly modified in order to more precisely predict rock mass ultimate strength state. Initially, the ultimate state was described in terms of uniaxial compressive or tensile strength; later a Mohr–Coulomb criterion was commonly accepted, and now, most promising, are physical characteristics measured at the conditions extremely close to natural ones (Alexeev and Nedodayev, 1982). However, it is

well known that the natural conditions of rock masses necessarily include a multiaxial stress state. Direct experimental measurements of mechanical parameters inside the rock mass are obviously difficult or even impossible. Therefore, experimental simulation using the experimental frames for true triaxial compression is currently the most informative and reliable for data acquisition in the prediction of rock mass behavior (Wawersik et al., 1997; Al-Harthy et al., 1999).

2. True triaxial loading apparatuses

2.1. First-generation TTAL apparatus

The first-generation unique experimental installation for true triaxial loading (1G-TTAL) was designed,

* Corresponding author. Donetsk Phys.-Tech. Institute, Academy of Sciences of Ukraine, 72 R. Luxemburg str., Donetsk 340114, Ukraine. Tel.: +7-380-0622-904-908; fax: +7-380-0622-557-626.

E-mail address: alexeev@host.dipt.donetsk.ua,
alexeev@oftpg.fti.ac.donetsk.ua (A.D. Alexeev).

manufactured, and tested in the early 1980s, as described by Lama and Bodziony (1996). It had a number of advantages over other prototypes presented by these authors, in particular in maximum mean stress and edge effects.

Three-dimensional image of IG-TTAL apparatus main unit is shown in Fig. 1 and the x, z cross section in Fig. 2. The base (1) bears the fixed supports 5, 11, and 16 providing a movement of receiving plates 4, 10, and 15 along the guides. The loading unit (beyond the figures) consists of three hydraulic cylinders oriented along three mutually perpendicular axes, their joining elements being connected with the thrusters 2, 7, 14 relating to the main unit. These thrusters convey loads from the loading unit to the loading plates 3, 6, and 12 and further to the specimen 8. They also act as guides for the loading plates. Receiving plates 4, 10, and 15 and the loading plates are equipped with springs (9).

The whole apparatus operates in the following way. Displacement of hydrocylinder pistons along the three mutually perpendicular axes towards the specimen causes respective displacements of loading plates 3, 6, and 12 overlapping each other and the carrying plates 4, 10, and 15.

For example, the loading plate 12 (x -axis) slides along the plate 6 and carries plate 10. Simultaneously, plate 12 is touching plates 3 and 15 to move them along the guides of the thruster (2) and corresponding support (16). Compressed springs (9) provide the

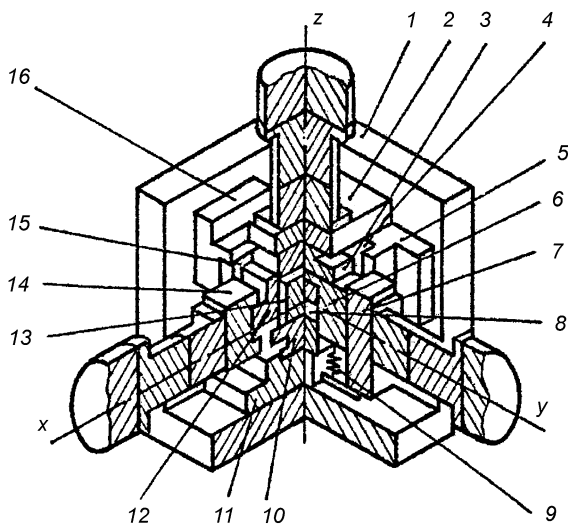

Fig. 1. 3D view of the main unit of IG-TTAL apparatus.

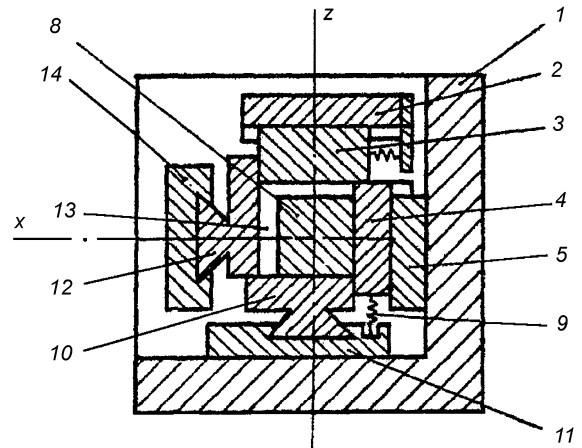

Fig. 2. Base (x, z) cross section of the main unit in Fig. 1.

constant contact between the loading plate 12 and plates 3 and 15. Two other cylinders (y - and z -axis) together with loading plates 3 and 6 operate the same way. As a result, the closed chamber (13) with the test specimen inside is formed. Compression of the specimen is provided by means of loading plates 3, 6 and 12 from one side and the carrying plates 4, 10 and 15 from another side, respectively, over the whole interface between these plates and specimen's faces. The table-mounted loading unit consists of the hydraulic cylinders and bases oriented along the three mutually perpendicular axes. The cylinders are attached to the bases by means of studs and flanges.

Highest possible pressure produced by each cylinder is about 250 MPa. The piston diameter is 250 mm. Hence, the force exerted to the piston can reach about 78 kN.

Although such designed had marked advantages over known prototypes, it also had some drawbacks. First of all, there were significant force drops on loading plates and frictional losses in pairs "support-carrying plate" and "loading plate-specimen".

Friction in the G-TTAL-apparatus assembly could be drastically diminished by means of substitution of rolling friction instead of sliding friction. This goal could be achieved by placing a roll support between the contacting surfaces. Estimated friction factor was 50 times lower as compared with the sliding tribological situation.

Consequently, change to rolling friction in the tribological pair "support-pressing or receiving plate"

could enable establishment of any desired relationships between three main stresses, neglecting friction losses in loading process. Moreover, apparatus performance would be enhanced due to the lower wear rate of cylinder pistons and sealing as well as higher accuracy of measurements.

2.2. Second-generation TTAL apparatus

The abovementioned drawbacks of 1G-TTAL apparatus were eliminated in the second generation apparatus (2G-TTAL) designed at the Institute for Physics of Mining Processes (former Division for Physical and Technical Problems of Mining) and Institute for Problems of Mechanics of Russian Academy of Sciences and patented by Aseyeva et al. (1987).

General view of 2G-TTAL apparatus is shown in Fig. 3 and its A-A cross section in Fig. 4. It consists of the following components:

- base (1) having shape of closed frame;
- the movable thrust beam (2) placed inside the frames;
- fixed receiving blocks (3 and 4) with the receiving plates;
- loading blocks (5–7) with the pressing plates attached to the base (1);

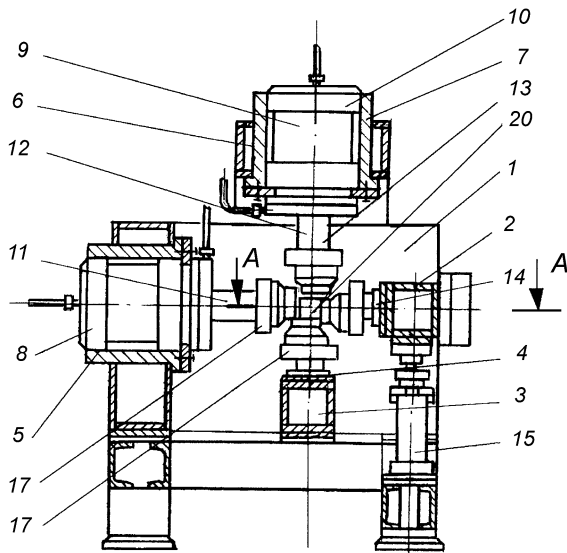

Fig. 3. Design of 2G-TTAL compression apparatuses.

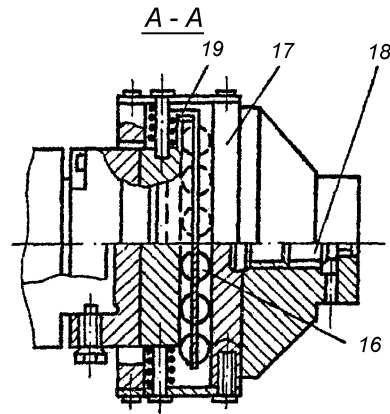

Fig. 4. A-A cross-section view of the support/pressing plate assembly in Fig. 3.

- power hydraulic cylinders (8–10) with rods (11–13) within the loading blocks (5–7, respectively);
- receiving block (14) attached to the beam (2);
- hydraulic cylinder (15) allowing to lift the beam 2;
- detachable adjustments heads (17) with the strain sensors (18) and springs (19) mounted on the pressing and receiving plates by means of roll supports (16).

The apparatus operates in the following sequence:

The test specimen (20) is placed into the space formed by the fixed receiving blocks 4 and 3 when beam 2 is in top position. Loading blocks (5–7) with attached adjustment heads (17) are in the initial positions. Specimen 20 being in place, the beam 2 together with the attached receiving block 14 is driven down by cylinder 15. Loading blocks 5–7 are now driven by cylinders 8–10 using rods 11–13. Each cylinder can operate independently in accordance with its own loading schedule.

In the course of an experiment, adjustment head 17 of loading block 5 slides over adjustment heads of loading block 7 and receiving block 3. Simultaneously, this head displaces adjustments of loading block 6 and receiving block 4 in the direction of force exerted by the cylinder 8. Adjustment heads of two other loading blocks (6 and 7) operate in the similar manner.

The springs (19) are compressed, ensuring permanent mechanical contact between adjustment heads of loading blocks 5–7 and receiving blocks 3, 4, and 14.

Specified pressure is applied over the entire surface of specimen 20. Desired stress state in the specimen 20 being attained, loading 5–7 are stopped.

Loading mode along each axis is independent and proceeds as follows. A pump generates pressure in a hydroaccumulator to suppress pulsations. Working fluid flows through pressure and flow-rate controllers to the multiplier providing boosting flow rate in the system. Each specimen loading schedule is implemented by the pressure and flow-rate controllers.

Having all loading and receiving blocks dismounted, one can install a high-pressure chamber designed to study mechanical properties of solids under complex stress state and simultaneous gas (e.g. methane or carbon dioxide) saturation. This allows simulating various gas or hydrodynamic phenomena in rocks, with the aim of developing methods of prediction and prevention of such phenomena.

Implementation of adjustment head mounted on the pressing and supporting plates with the roll supports (see Fig. 4) decreases loading and receiving blocks wear rate and prevents cylinder piston seizure

due to displacement caused by friction between the specimen and pressing parts. As a result, measurement accuracy has been drastically increased. Detachable design of adjustment heads allows to test specimens of various sizes.

3. Results and discussion

3.1. Effects of absorbed water on stress state parameters in coal

As stated above, TTAL apparatuses can be used to simulate stress state of rock mass at the near-face region of coal seam where the outburst-hazardous situation is generally formed. Experimental stress measurements in both gently and steeply dipping coal seams as well as the analytical solutions show that coal seam margins are generally in the nonuniform stress state (Alexeev et al., 1989). Hence, the loading mode in laboratory tests should correspond to the natural conditions, namely $\sigma_1 \neq \sigma_2 \neq \sigma_3$.

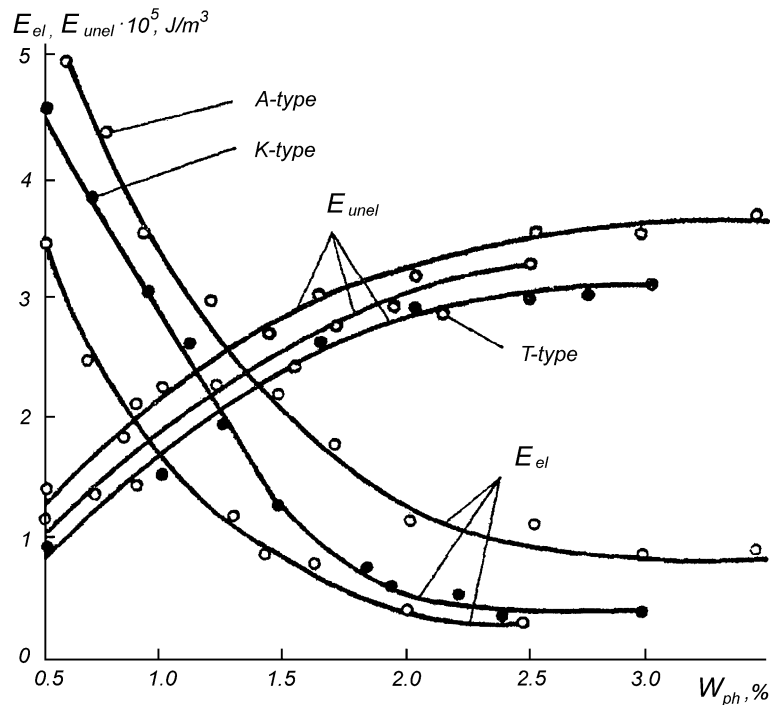

Fig. 5. Influence of adsorbed water content on specific accumulated elastic energy E_{el} and inelastic absorbed energy E_{inel} under three-dimensional loading of specimens of different coal types.

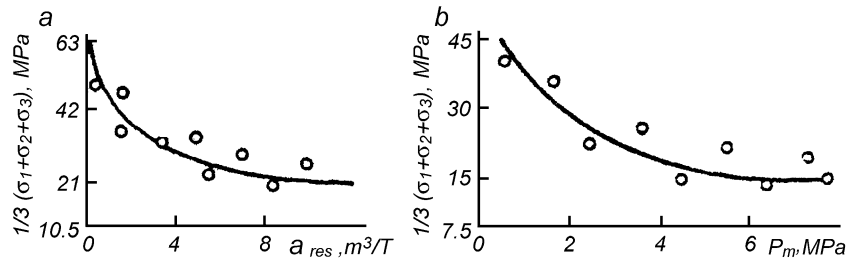

Fig. 6. Compressive strength vs. residual gas content (a) and compressive strength vs. gas pressure (b) in a coal specimen under conditions simulating outburst.

In the first trials, coal specimens were compressed uniformly with $\sigma_1 = \lambda\sigma_2 = \lambda\sigma_3$ in order for reproducing virginal coal mass condition. Then first two stress components were increased up to $\sigma_1 = KP_2$ and $\sigma_2 = \lambda KP_2$, the third one (σ_3) decreased, imitating underground cavity. Here K is stress concentration factor (for the steep coal seams $K = 1.8\text{--}2.5$); P_2 is a rock pressure at the given depth; and λ is the lateral thrust coefficient. Tests in both loading modes were conducted using specimens of coking (K), lean (T) and anthracite (A) type coals (National Standard of Ukraine DSTU 3472-96, 1997) humidified in as-delivered or outgassed condition. It was found that for coal type T increase in absorbed water content from 0.4% to 2.5% amplifies the average strain by a factor of 2–3 and reduces the bulk modulus by a factor of 2.5 to 3. Investigations of coal behavior under three-dimensional stress state have revealed that complete unloading causes volume increase of gas-saturated specimens of 2% to 3% while the volume of water-saturated specimens remains constant. These results indicate that physical processes in coal structure at the increased content of absorbed water are irreversible.

Graphs illustrating the influence of absorbed water content on accumulated elastic energy at the bulk loading simulating conditions at the near-face zone of coal mass are presented in Fig. 5. Experimental data show that the amount of elastic energy available for release at unloading is decreased by factor of 3.5 for A type coal or by factor of 6 for the types of K and T at water content increase from 1.0% to 2.5%. It can be concluded that each coal type can be characterized with the critical absorbed water content value that decrease its elastic and effective surface energies so strongly that they can bring the coal into an outburst-safe state.

Similar test using TTAL apparatus and various specific rock or coal samples make it possible to determine the critical physically bound water content necessary to suppress the coal gas dynamic activity. It can be demonstrated from the latter preliminary experiments that the highest strength, strain and accumulated energy drop in coal takes place at the absorbed water content within 2% to 3% depending on coal type.

3.2. Effect of adsorbed methane on simulated outbursts in coal

It is known from coal mining practice at outburst-hazardous seams as well as from existing supposed

Table 1
Characteristics of coal specimens used for simulation methane-promoted coal outburst

Absorbed water content (%)	Residual gas content (m^3/t)	Mean applied stress (MPa)	Average particle size at outburst (mm)	Number of specimens
0.6–0.8	0	60.0	0.17–0.23	15
	3.5–4.5	36.5		
	6.5–7.5	29.5		
	9.5–10.5	22.0		
1.2–1.4	0	60.0	0.58–0.71	12
	3.5–4.5	36.5		
	6.5–7.5	29.5		
	9.5–10.5	22.0		
1.6–1.8	0	60.0	1.8–2.25	10
	3.5–4.5	36.5		
	6.5–7.5	29.5		
	9.5–10.5	20.0		
2.0–2.8	0	60.0	No outburst like fracture of the specimen's face	5
	3.5–4.5	36.5		
	6.5–7.5	29.5		
	9.5–10.5	22.0		

outburst mechanism that sudden coal outbursts are necessarily accompanied by gas dynamic phenomena, gas taking active participation in both outburst nucleation and final progress. The 2G-TTAL apparatus has been used to simulate the outburst-type of gas-saturated coal specimens with different absorbed water content in order to estimate the influence of free or absorbed methane on gas dynamic activity in coal. These experiments have been carried out using a high-pressure chamber able to provide complete or partial unloading of one specimen's face. The apparatus could reproduce the outburst-type fracture at different methane pressures and different stress states. Coal specimens with natural moisture of 0.6% to 0.8% or artificially humidified up to 2% to 3% moisture had been studied.

The curve in Fig. 6a presents critical means stress corresponding to a partial outburst-like fracture of specimens face as a function of residual gas content a_{res} . It can be seen that presence of methane in the coal structure decrease this critical stress as well as average coal particle size in the thrown mass (see Table 1). The latter was within 0.17 to 0.23 mm, closely matching those found in the gas dynamic phenomena in mines. Data points in Fig. 6a were plotted using minimum stress or water content values and maximum residual gas content. It should be noted that methane present in coal structure exerts no influence on fracture beginning from water content value about 2.0%, see Table 1. At water content value of 1.8% thrown particle size becomes larger by factor of 10 or more; while at water content 2% or more the outburst-type fracture disappears. Similar curve in Fig. 6b shows dependence of the critical mean stress on methane pressure.

4. Conclusions

Advance true triaxial loading apparatus or installations are very promising instruments in geophysical studies and underground mining. Artificial outburst-type fracture mode can be reproduced using second-generation TTAL apparatus by means of unloading one face of a solid specimen in true triaxial stress state. Studies of absorbed water and/or adsorbed methane effects on parameters of such fracture in coals permits to predict outburst conditions in specific coal seams and to prevent them based on the finding that water absorption higher than about 3% makes the outburst-type fracture mode impossible.

References

- Al-Harthy, S.S., Jing, X.D., Marsden, J.R., Dennis, J.W., 1999. Petrophysical properties of sandstones under the triaxial stresses: I. directional transport characteristics and pore volume change. SPE Asia Pacific Improved Oil Recovery Conference, Kuala Lumpur, Malaysia, 25–26 October 1999. Paper No. SPE 57287.
- Alexeev, A.D., Nedodayev, N.V., 1982. Ultimate State of Rocks Naukova dumka, Kiev (in Russian).
- Alexeev, A.D., Revva, V.N., Ryazantsev, N.A., 1989. Rock Fracture in Bulk Compressive Stress Field Naukova dumka, Kiev (in Russian).
- Aseyeva, T.P., Alexeev, A.D., Viktorov, V.V., Stratikov, G.P., 1987. A plant for three-axis compression tests of prismatic specimens. U.S.S.R. Patent No. 1285340. Priority 1984 (in Russian).
- Lama, R.D., Bodziony, J., 1996. Outburst of Gas, Coal, and Rock in Underground Coal Mines Westonprint, Kiama, NSW, Australia.
- National Standard of Ukraine DSTU 3472-96, 1997. Brown, Bituminous, and Anthracite Coals: Classification State Office of Standards, Kiev, Ukraine.
- Wawersik, W.R., Carlson, L.W., Holcomb, D.J., Williams, R.J., 1997. New method for true triaxial rock testing. Int. J. Rock Mech. Min. Sci. 34 (3–4), 365.