

Ground deformation at Campi Flegrei, Italy: implications for hazard assessment

FRANCESCA BELLUCCI¹, JUDITH WOO², CHRISTOPHER R. J. KILBURN² &
GIUSEPPE ROLANDI¹

¹*Dipartimento di Geofisica e Vulcanologia, Università di Napoli, Via Mezzocannone 8,
80034 Napoli, Italy*

²*Benfield Hazard Research Centre, Department of Earth Sciences, University College
London, Gower Street, London WC1E 6BT, UK (e-mail: j.woo@ucl.ac.uk)*

Abstract: Campi Flegrei caldera, west of Naples in southern Italy, has an exceptional documented record of ground deformation from Roman times onwards. Systematic recording began in the nineteenth century. For earlier dates, information has been obtained from archaeological studies and from contemporary descriptions of the locations of buildings, usually Roman, with respect to sea-level. Especially important have been accounts related to the Serapis, a Roman market-place built in the second century BC and now incorporated within the modern town of Pozzuoli. The long-term patterns of ground deformation have conventionally been investigated on the premise that Campi Flegrei naturally tends to a state of static equilibrium. This study argues that, instead, the area naturally tends to a steady rate of subsidence, at about 17 mm a⁻¹. After this background rate has been removed, the data indicate that a permanent uplift of some 33 m has occurred from Roman times (up until the present day: 2005 at the time of writing), attributable to the intrusion of 1.85 km³ of magma, of which only 1% has been erupted. Uplift has occurred in three episodes, the third of which is still in progress. The behaviour can be interpreted in terms of the intermittent ascent of magma between a reservoir of c. 10²–10³ km³ at depths of 8–15 km or greater, to a much smaller, shallower system at depths of about 3–4 km. Should the current pattern of deformation follow previous trends, uplift is expected to continue for another 80–90 years, during which time Campi Flegrei will be characterized by an elevated possibility of eruption.

Campi Flegrei is a volcanic field immediately to the west of Naples in southern Italy. Active for at least 50 000 years (Cassignol & Gillot 1982; Rosi & Sbrana 1987), the field covers some 200 km², of which the south-central third is now submerged beneath the Bay of Pozzuoli (Fig. 1). The area is dominated structurally by a caldera, 6 km across, produced during the eruption of the Neapolitan Yellow Tuff (NYT), a 40 km³ (DRE: dense rock equivalent) ignimbrite of K-trachyte–phonolite composition (Rosi *et al.* 1983; Di Girolamo 1984; Orsi *et al.* 1995). This event is conventionally dated at about 12 000 a BP, although an older age of 15 600 a BP has recently been proposed by Deino *et al.* (2004). Caldera collapse may also have occurred during eruption of the 150 km³ (DRE) Campanian Ignimbrite at about 39 000 a BP, although the link between Campi Flegrei and this eruption remains controversial (Rosi *et al.* 1983; Di Girolamo *et al.* 1984; D'Antonio *et al.* 1999; Rolandi *et al.* 2003). Eruptions since the NYT event have produced mainly monogenetic strombolian and hydromagmatic cones, as well

as subordinate lava domes. Most of these eruptions expelled c. 0.1–1 km³ (DRE) of alkali-trachyte or phonolite; a small number have also occurred with volumes of c. 0.01 km³ (DRE), some of which erupted K-trachybasalt (Fig. 2; Rosi *et al.* 1983; Lirer *et al.* 1987).

Post-NYT events across the caldera floor have been clustered in time: some 34 eruptions occurred between the NYT eruption and 9500 a BP, six eruptions between 8600 and 8200 a BP, and 16 eruptions between 4800 and 3800 a BP (Di Vito *et al.* 1999). Since 3800 a BP, the only eruption in Campi Flegrei has been that of Monte Nuovo in 1538 (Fig. 2; Rosi *et al.* 1983; Di Girolamo *et al.* 1984; Di Vito *et al.* 1999).

Campi Flegrei has also undergone several episodes of subsidence and uplift since the NYT eruption (Cinque *et al.* 1985; Rosi & Sbrana 1987; Dvorak & Mastrolorenzo 1991). The most recent movements occurred during the intervals 1969–1972 and 1982–1984 and involved, respectively, maximum uplifts of 1.7 and 1.8 m. Although neither episode culminated

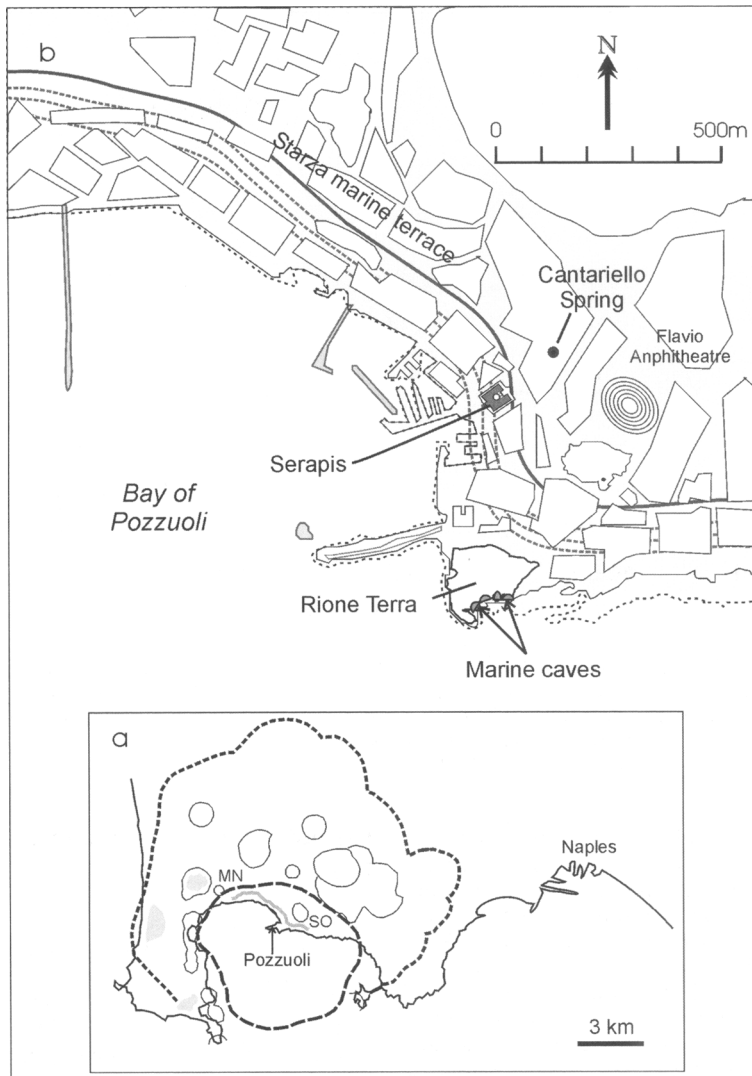

Fig. 1. Location maps for key sites in Campi Flegrei. (a) Pozzuoli lies in the northern half of the caldera produced by the NYT eruption (large dashes); a larger caldera (small dashes), inferred from modern topography, has been proposed as the source for the Campanian Ignimbrite (e.g. Rosi *et al.* 1983), although seismic tomographic surveys have since suggested that this feature is superficial only (Judenhrc & Zollo 2004). The principal eruptive centres since the NYT eruption (*solid lines*) are scattered across the caldera floor. The Starza terrace (*grey line*) runs between Monte Nuovo (MN) and Solfatara (SO) parallel with the coast behind Pozzuoli. (b) Data for historic ground movements in Pozzuoli have been obtained from the Serapis archaeological site and from caves by the *Rione Terra*. Also shown is the location of the Cantariello spring, which was closer to the coast in the fifteenth Century (Fig. 6), indicating a net ground uplift since that time.

in an eruption, they both raised concern about imminent volcanic activity. Indeed, a pressing question remains as to the precursory conditions that must be fulfilled for an eruption to take place.

In this paper, we reconsider the pattern of ground movements at Campi Flegrei since

Roman times, in order to identify constraints for better evaluating the likelihood of a future eruption. The study builds on the comprehensive review by Dvorak & Mastrolorenzo (1991), incorporating new data from historical documents, as well as archaeological information from Morhange *et al.* (1999) that has yet to be

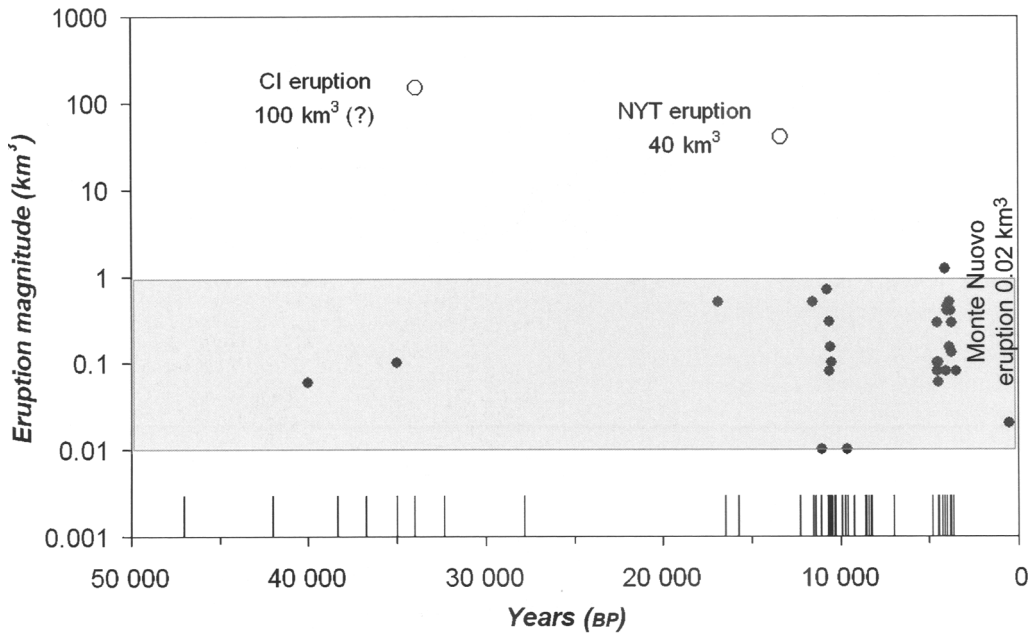

Fig. 2. Magnitude of eruptions from the Campi Flegrei caldera in the past 50 000 years. *Solid circles* represent eruptions with known volumes, and *straight lines* those eruptions for which volumetric data are not available. Apart from the Campanian Ignimbrite and NYT eruptions (*open circles*), the majority of events with known volumes (both before and after caldera formation) have volumes of 0.1–1 km³ (*shaded*). Data from Di Girolamo *et al.* (1984), Lirer *et al.* (1987) and Di Vito *et al.* (1999).

integrated into the volcanological literature. The data suggest that the district is naturally subsiding at about 17 mm a⁻¹, and so, to investigate the processes controlling variations in deformation rate, this background value must first be subtracted from observed movements. The analysis thus contrasts with previous studies, all of which have assumed implicitly that Campi Flegrei should naturally remain in a stationary condition (*e.g.* Parascandola 1947; Dvorak & Mastrolorenzo, 1991; Morhange *et al.* 1999; Orsi *et al.* 1999).

The results support the argument of Morhange *et al.* (1999) that Campi Flegrei underwent two episodes of major uplift between Roman times and the sixteenth century. The uplift involved a total permanent displacement of about 33 m, and can be attributed to the injection to shallow depth (about 3–4 km) of some 1.85 km³ of magma – a volume 100 times greater than the amount expelled in 1538 by the only eruption during the same period (Di Vito *et al.* 1987). They also suggest that the smaller uplifts since 1969 represent the early stages of another major episode; if verified, this inference implies that, compared with the interval since 1538, the twenty-first century will be characterized by an elevated probability of eruption.

Reconstructing ground movement in Campi Flegrei

Three key points of reference for reconstructing ground movement in Campi Flegrei are located in and around modern Pozzuoli, on the coast of the Bay of Pozzuoli 13.5 km west of Naples (Fig. 1). These are: (1) the cliff of La Starza, which, set about 300 m inland, runs some 3 km west from Pozzuoli, subparallel with the coast-line; (2) Serapis, a Roman market-place built in 200 BC in Pozzuoli; and (3) the old town of Pozzuoli (founded as a Greek colony by at least the sixth century BC), or *Rione Terra*, built on a promontory about 500 m south of Serapis (Fig. 1). These nearby locations are important because levelling surveys since at least 1905 (Dvorak & Mastrolorenzo 1991) suggest that the onshore pattern of elevation changes across Campi Flegrei has been remarkably consistent, with episodes of both subsidence and of uplift showing a broadly radial decay in vertical deformation away from Pozzuoli to the edge of the volcanic field. In detail, numerical simulations by Troise *et al.* (2004) suggest that, due to the presence of ring-faults around the caldera rim, the rate of radial decay during uplift will be

different from that during longer-term episodes of subsidence. Assuming similar patterns for earlier episodes of subsidence and uplift, therefore, elevation changes inferred for the Pozzuoli district can be taken as representative scales for deformation across the whole caldera.

Prehistoric ground movement

Raised marine terraces along the Starza cliff behind Pozzuoli demonstrate that Campi Flegrei has experienced episodes of subsidence and of uplift between the NYT eruption and Roman times (Rosi *et al.* 1983; Di Girolamo *et al.* 1984; Cinque *et al.* 1985; Rosi & Sbrana 1987). Within the exposed cliff, Cinque *et al.* (1985) recognized three marine horizons, separated by sub-areal tephra layers. The lowest marine horizon has been dated stratigraphically to about 8400 a BP (Cinque *et al.* 1985), whereas a shell in the uppermost marine layer has a radiocarbon age of 5345 ± 150 a BP (Rosi & Sbrana 1987); accordingly, the three horizons must have been separated by at least two episodes of subsidence followed by hiatuses to produce the marine terraces. Starting at about 5345 a BP, all three horizons were raised out of the sea. Today, the Starza terrace stands about 30 m above sea-level (Cinque *et al.* 1985).

The Starza terraces developed during a period of low volcanic activity, between the clusters of eruptions during 8600–8200 a BP and 4800–3800 a BP. Thus, assuming in particular that the youngest uplift that took place in 5345 a BP was caused by movement of magma, it must also have coincided with conditions favouring shallow magma intrusion, rather than eruption. Such a possibility is of interest because, as discussed below, uplift since Roman times may have been taking place under similar conditions.

Historic ground movement

Since the last Ice Age, mean sea-level in the Mediterranean has been rising at an average rate of $0.2\text{--}0.6\text{ mm a}^{-1}$, giving an increase in sea-level of no more than 1 m since Roman times (Dvorak & Mastrolorenzo 1991). As shown below, such a variation is negligible compared with the displacements inferred for Serapis, confirming that the movements are indeed the result of changes in ground level.

Ground movement at Serapis has been monitored systematically by a variety of techniques since the early 1800s (Niccolini 1839 *in* Dvorak & Mastrolorenzo 1991). The data show that, until the late 1960s, the Pozzuoli area was subsiding at a mean rate of 17 mm a^{-1} (Fig. 3).

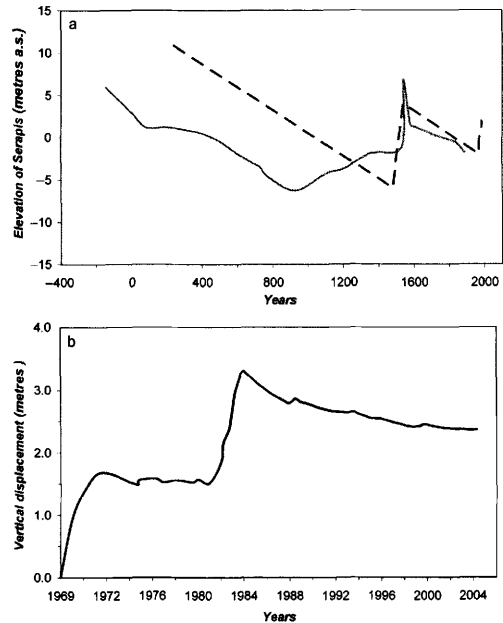

Fig. 3. Vertical elevation changes in Pozzuoli in historical times. (a) Several trends have been proposed from fragmentary historical data since Roman Times. Shown here are the classic curve (grey) due to Parascandola (1947), extended to 2004 (see (b)), and the reconstruction (horizontal lines) by Dvorak & Mastrolorenzo (1991). The 1538 spike in Parascandola's curve coincides with the uplift inferred to have occurred days before the eruption at Monte Nuovo. This uplift was temporary and located some 3 km WNW of Pozzuoli (Fig. 1) and so is not representative of the long-term trends inferred for Serapis by the rest of the curve. (b) Changes in vertical displacement at Pozzuoli between 1969 and 2005 (data from F. Pingue, INGV-Osservatorio Vesuviano). Two episodes of bradyseismic events in 1969–1972 and 1982–1984 produced uplifts of 1.7 m and 1.8 m respectively. The area of Pozzuoli has since been subsiding at a gradually decreasing rate, reaching a mean value of less than 17 mm a^{-1} between 2003 and 2005. An adjusted curve is shown in Figure 7.

The trend was reversed in 1969, when the Serapis was raised 1.7 m in just three years. Following a subsidence of 0.22 m between 1972 and 1982, a new 30-month phase of uplift raised the Serapis by another 1.8 m, since when it has again been subsiding at a decaying rate, from about 160 mm a^{-1} between 1985 and 1988 to about 30 mm a^{-1} during 1996–2002 (Fig. 4; F. Pingue, INGV-Vesuvius Observatory, pers. comm. 2005). Interpretations of pre-1800 movements at Serapis follow the pioneering studies of Parascandola (1947) and infer that deformation has been characterized by a subsidence of about

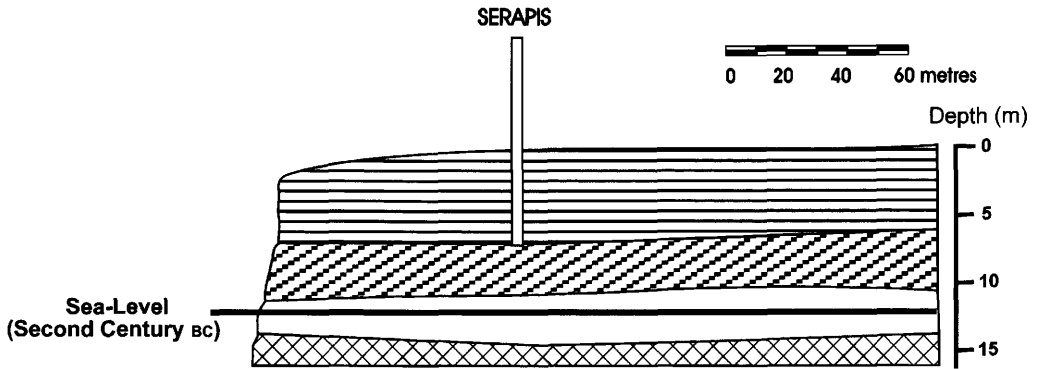

Fig. 4. Cross-section showing the stratigraphy of Serapis and surrounding area, looking NW (coast to left). Four layers can be distinguished: (1) 6.2 m of reworked yellow tuff and Roman artifacts in a sandy matrix (*horizontal lines*); (2) 4.3 m of gravel beds, composed of reworked yellow tuff and fragments of marble, tiles and pottery of Roman age (*diagonal lines*); (3) 2.5 m of alluvial deposits with rounded fragments of Roman pottery (*white*); and (4) 2.5 m of pyroclastic deposits with rounded pumice lapilli (*cross-hatched*). Layers 1–3 are interpreted as Roman waste deposits. The black line marks approximate sea-level during the construction of Serapis; it also shows that part of Layer 3 was laid down underwater. During excavation, the columns of Serapis were found to be buried by the Layer-1 deposits. The Cantariello thermal spring (Figs 1 & 6) lies about 130 m NE of Serapis (to the right).

12 m from 200 BC until sometime around 900 AD, followed by 12 m of uplift until the 1538 eruption of Monte Nuovo, the most recent event in Campi Flegrei, and then about 4 m of subsidence until the first geodetic measurements in the early 1800s (Fig. 3; Dvorak & Mastrolorenzo 1991; Orsi *et al.* 1999). Such interpretations, however, interpolate data for the Pozzuoli district from before 530 AD and after 1441 (Fig. 3; Dvorak & Mastrolorenzo 1991), and so are poorly constrained between these dates (a consequence of few documents surviving the political turbulence of the period; Dvorak & Mastrolorenzo 1991). In the following sections, we present new data covering the interval 530–1441 (Table 1), including those reported in the archaeological literature by Morhange *et al.* (1999).

Geology of the Pozzuoli area

The Pozzuoli area stands on a sequence of eruptive units down at least to the Neapolitan Yellow Tuff (Lirer *et al.* 1983). At *Rione Terra*, the NYT consists of layered pyroclastic deposits that dip 25–30°S and indicate emplacement over a relict volcanic structure. The NYT, in turn, is overlain by a thick, grey, incoherent and massive ash layer, known locally as *pozzolana*, and then by sequences of marine deposits (laid down after volcano-tectonic collapses or extended periods of subsidence; Cinque *et al.* 1985) and sub-areal fallout tephra from eruptions in Campi Flegrei (Di Girolamo *et al.* 1984).

Towards the Serapis, drill cores show that the volcanic sequence is overlain by about 13 m

of reworked sediment (Fig. 4). The lower 6.8 m consists of 4.3 m of gravel (composed of fragments of yellow tuff, pottery, tiles and marble) resting on 2.5 m of alluvial deposits with rounded fragments of pottery; the upper 6.2 m consists of grey, silty-sandy beds with small, and mostly rounded, fragments of artifacts. The levels above the alluvial deposits are interpreted to be the remains of a Roman rubbish dump that extended from the beach to the base of the Starza cliff.

The Serapis itself rests on the gravel layer. The initial dump may therefore have been designed as a surf-lip structure, providing the embankment on which the Serapis was constructed; the lowest elevation of the original (mosaic) Serapis floor can thus be estimated at about 5.8 m a.s.l. The smaller grain size and greater rounding of the upper 6.2 m suggests that this level marks a reworked horizon, produced by increased wave action after the area began to subside below sea-level. Importantly, the drill cores provide no evidence for significant volcanic deposits on top of the sediments. This conflicts with Parascandola (1947), who identified some 3 m of volcanic material at the surface around Serapis and attributed the deposit to the 1538 eruption of Monte Nuovo, about 3 km to the WNW. However, in addition to the drill cores, no evidence of such a volcanic horizon has been found by more recent field studies (De Vito *et al.* 1987, 1999) and so it appears to be the result of a misidentification. Accordingly, the depth of burial of structures at Serapis has not been determined by the emplacement of primary volcanic units.

Table 1. Sources for estimating the elevation of the Serapis district

Year	\pm Range in years	Location	Description	Elevation of marble floor of Serapis (m a.s.l.)	Range (m)	Ref.*
200 BC	?	Serapis	Marble floor built on at > 5 m of gravel beds and 2.11 m above mosaic floor	8.1	2.5	3
80 AD	?	Serapis	Construction of marble floor during the Flavian Epoch	3.1	1.0	3
203	8	Serapis	Major restoration by Septimus Severus; construction of sea embankments	1.0	1.0	1
228	7	Serapis	Major restoration by Alexander Severus; construction of sea embankments	0.5	1.0	1
430	97	Serapis	Radiocarbon dating of mollusc borings on marble columns	-7.0	1.5	2
791	97	Rione Terra	Medieval foundation built on perforated Roman structure	1.5	1.5	2
1395	59	Rione Terra	Radiocarbon dating of mollusc borings on walls of marine cave	-7.0	1.5	2
1430	?	Serapis	Parts of columns exposed in painting 'Bagno del Cantariello'	-10.0	1.0	3
1522	15	La Starza	Engraving by Franz Hogenburg showed scene before 1538 eruption and La Starza	1.0	1.0	3
1538	0	Pozzuoli	Monte Nuovo eruption	4.0	1.0	1

Refs*: 1 = Dvorak & Mastrolorenzo (1991); 2 = Morhange *et al.* (1999); 3 = new data.

Reference horizons at Serapis

Excavations at Serapis began in 1750 (Breislak 1792; Dvorak & Mastrolorenzo 1991). Covering some 55 × 70 m², the site was buried by 9 m of sediment. Today, it is dominated by three marble columns, each 13 m tall, at the northeastern end of the market (Fig. 5). The columns form part of a temple, the *Aedes Serapis*, the foundations of which mark the first stage of construction on the site (according to an inscription found nearby, the *Lex Parieti Facendo*). The initial foundation supported a mosaic floor, dated to the second century BC (Levi 1969; Dvorak & Mastrolorenzo 1991). The mosaic floor lies 2.11 m beneath a second floor of marble, constructed around 80 AD during the Flavian epoch (Maiuri 1937). Since a Roman drainage structure underlies the mosaic floor by 0.66 m, the original mosaic floor in 80 AD may have been at about 1 m above sea-level (Sicardi 1979), indicating that the new marble floor was about 3 m a.s.l. A central

rotunda with small standing columns (the *Pronao*; Fig. 5) was added between the second and third centuries AD, when the area was being used as a market. During this period, two coastal embankments were built by Valerio Massimo in 230 AD, apparently to protect the site from the sea (Parascandola 1947; Dvorak & Mastrolorenzo 1991). This suggests that the contemporary marble floor was close to sea-level (nominally about 0.5 m a.s.l.).

Fig. 5. The floor plan of Serapis (lower left) as drawn by Babbage (1847). The three standing columns (shaded circles) lie to the northwest (inland side) of the central rotunda, or *Pronao*. The columns (top and lower right) are 13 m high; each has been burrowed into by *L. lithophagus*, leaving a zone of pockmarking about 3 m thick (dark horizons in photo), the base of which is 3 m above the marble floor of the Serapis. The photo has been taken looking SW, towards the sea. (Photo: C. R. J. Kilburn.)

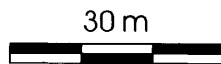
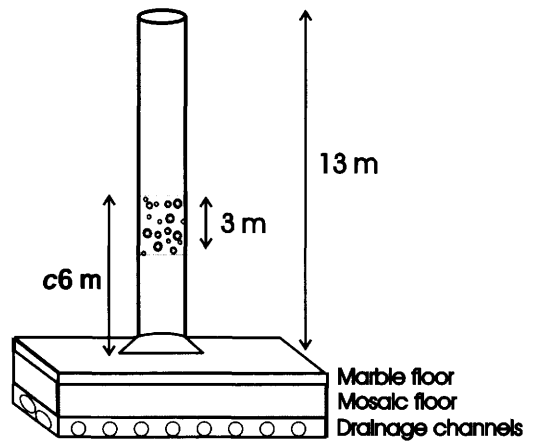
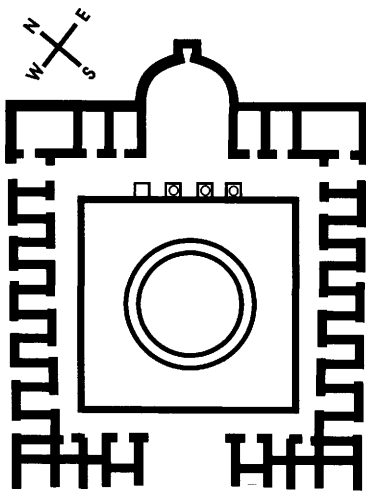

In addition to the two floors, a remarkable reference horizon for sea-level is provided by the three 13-m columns. Each has been perforated by marine bivalves (notably *Lithodomus lithophagus*) over a vertical thickness of about 3 m – the base of which stands 3 m above the marble floor (Fig. 5). Because the bivalves naturally flourish just below sea-level, the perforations indicate that the columns must have sunk into and re-emerged from the sea at least once since their construction – a conclusion readily appreciated by early geological studies (e.g. Forbes 1829; Niccolini 1845; Babbage 1847; Lyell 1872; Flemming 1969).

The lack of perforations down to the marble floor may reflect that, during initial submergence, local conditions were unsuitable for colonization (Babbage 1847). For example, *L. lithophagus* lives on limestone rocks, avoids brackish water and prefers to colonize steep surfaces on which the rate of sedimentation is low and local currents are strong (Šimunović & Grubelić 1992). During the first stages of immersion, therefore, water conditions may have been too brackish, or sediment rates too high, for successful colonization. The columns would thus have been surrounded by sediment and so protected from bivalve activity until after the water conditions had finally become suitable.

Movements at Serapis and Rione Terra: second century BC–fourteenth century AD

Construction of the two floors and the protective sea embankments suggest that the marble floor of Serapis had subsided about 2.5–3 m between 80 AD and 230 AD (Table 1), indicating a mean rate of subsidence of 17–20 mm a⁻¹. Movement of the *mosaic* floor, assumed to have been at about 6 m a.s.l. upon construction (second century BC), and about 1.5–2 m below sea-level in 230 AD, yields values for the mean rate of subsidence of between 15 and 21 mm a⁻¹. The similarity of the estimates supports the elevations inferred from the Roman structures and suggests that, for at least 300–400 years, the district have been subsiding at an almost constant rate.

Such rates of subsidence are further consistent with radiocarbon-based dates of 415–665 AD for *Lithophaga* shells taken from the tops of the perforated layers of the 13-m columns at Serapis (Morhange *et al.* 1999), in spite of the popular notion that all shells had long since been removed by collectors. The sampled levels stand about 6 m above the marble floor, indicating a subsidence of at least 5.5–6 m since 230 AD and yielding a subsidence rate of 22 ± 10 mm a⁻¹, which covers

the range of mean values inferred for earlier rates of subsidence.

Morhange *et al.* (1999) obtained a second set of radiocarbon dates for a coral *Astroides calycularis*, collected from a marine cave near *Rione Terra* at the same elevation as for the samples from the Serapis. The calculated dates lie between 1228 and 1367 AD, indicating that the marble floor of Serapis must have been at about 6 m below sea-level at sometime during this period.

Superficially, the bivalve and coral ages might suggest a single change from subsidence to uplift at sometime between the older and younger samples. However, archaeological studies of late medieval buildings (post fifteenth century AD) in *Rione Terra* have revealed that some foundations, encrusted by marine shells, have been dug into sediments overlying the ruins of Roman buildings. The sediments have been dated to between the eighth and tenth centuries AD by ceramic remains (Morhange *et al.* 1999). The encrustations are obviously younger than the medieval foundations. Hence, given that the foundations were not dug underwater, the post-Roman sediments must have emerged from the sea and been dug into, before resubmerging, to allow encrustation of the foundations, and then re-emerging above sea-level to their present position. Thus, between submergence in late Roman times and emergence before the 1538 eruption of Monte Nuovo, the coastal zone of Pozzuoli must have undergone at least one additional episode of uplift above and sinking below sea-level (the theoretical possibility of which had been recognized by Dvorak & Mastrolorenzo 1991). In addition, the lack of bivalves younger than 415–665 AD at Serapis suggests that, before subsequent episodes of re-emergence, either local water conditions had again become unfavourable, or the columns had been buried to depths of at least 6 m by sediments (to cover the existing perforated levels; Morhange *et al.* 1999).

Movements at Serapis and Rione Terra: fifteenth century AD–1538

Following Dvorak & Mastrolorenzo (1991), the maximum submersion of the Pozzuoli area has commonly been placed at the beginning of the century, before the onset of sustained uplift that ended with the 1538 eruption (Fig. 3). Commonly quoted is an ancient text, which states that in 1441 ‘the sea covered the littoral plain today called Starza’ (De Jorio 1820; Della Rocca 1985; Dvorak & Mastrolorenzo 1991), from which several authors have inferred a maximum submersion of about 6 m for the marble floor of Serapis during this period (Gunther 1903, 1904; De Lorenzo 1904; Maiuri 1937).

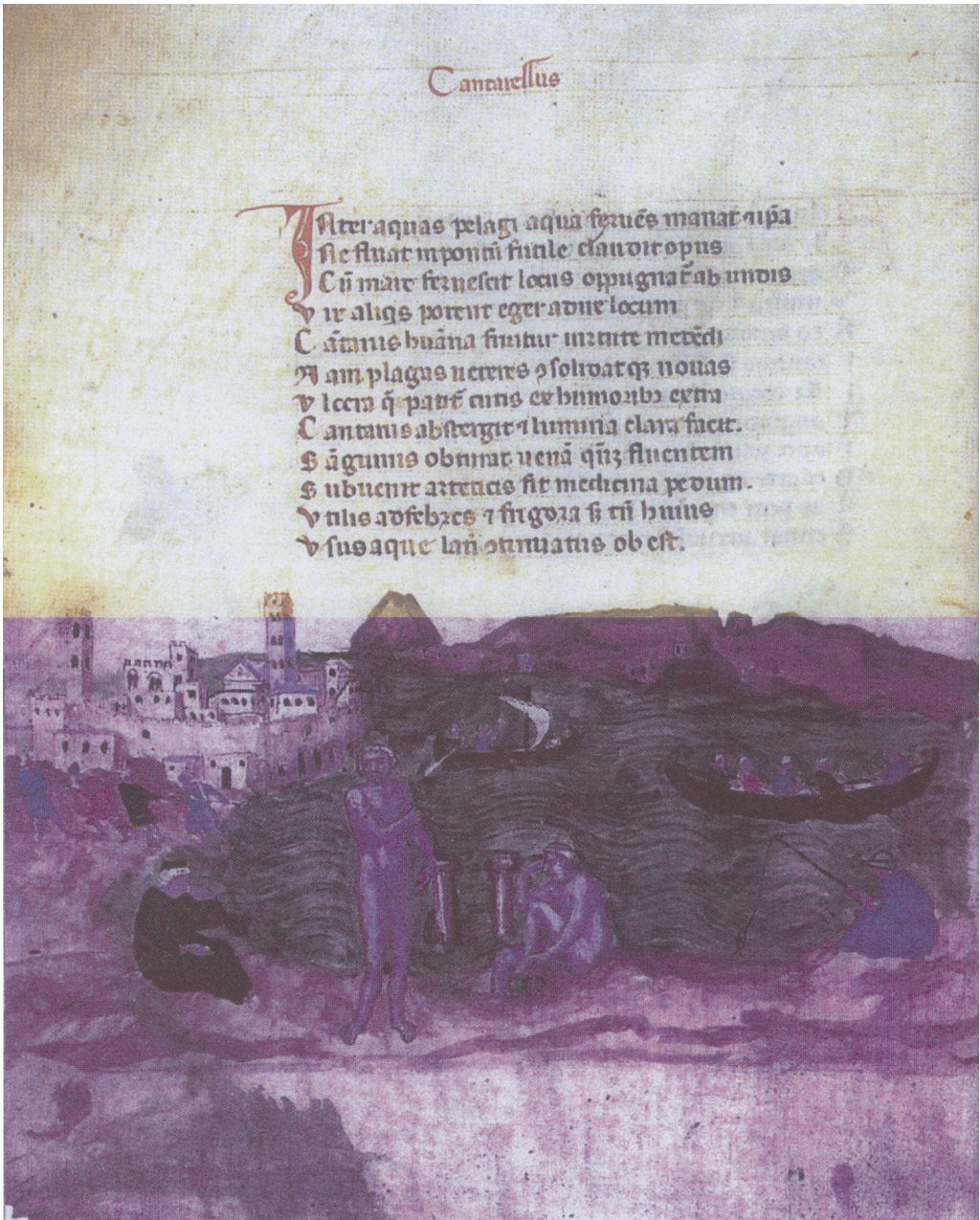

Fig. 6. Engraving from 1430 of the Cantariello thermal spring and its surrounding area, looking approximately SSW (Fig. 1). Rione Terra, the old town of Pozzuoli, is on the left. The tops of two of the columns at Serapis (about 130 m distant; Fig. 1) are clearly visible behind the figures in the foreground.

The maximum-depth estimates can be refined by new data from the 1430 engraving *Bagno del Cantariello* (Fig. 6), part of the famous *Balneis Puteolanis* of the Edinburgh Codex (Di Bonito &

Giamminelli 1992). The engraving depicts the *Rione Terra* encircled by vertical yellow tuff walls, from which the beach of *Marina Della Postierla* extends (towards the viewer) to the base

of the *S. Francesco* hill, the source of the thermal spring *Cantariello* (foreground) near the coast northeast of the submerged Serapis.

Behind the visitors to the thermal spring, the engraving clearly shows the upper few metres of the marble columns of Serapis rising from the sea (Fig. 6). Also depicted are people fishing directly from the shore. It is thus likely that the water around the columns, about 130 m offshore (Fig. 1), may have been as much as 1–2 m deep. The sea-floor coincides with the top of the sediments surrounding the columns. From the 1750 excavations, the final sediment thickness is estimated at 9 m. Given that most of this thickness (nominally at least 8 m) must have been accumulated before the top of the sediments re-emerged above sea-level, it is likely that, at the time of the 1430 engraving, the marble floor lay between 9 and 11 m below sea-level (3–5 m greater than had previously been inferred). The corresponding heights of the exposed parts of the 13-m columns would thus have been about 4 and 2 m – consistent with their prominence in the engraving. At the same time, some sections of the columns must have been in direct contact with water (between sea-level and the sea-floor). Apparently, therefore, local currents were too slow or sediment loads too high for successful recolonization of the columns by *L. lithophagus*, so preventing their additional perforation at high level. The marble floor of the Serapis was again close to sea-level by 1503, when a royal edict ceded to Pozzuoli the new land that had emerged off the shore of the port (Dvorak & Gasparini 1991). Uplift continued until the 1538 eruption. The elevation of Serapis at this time can be estimated by extrapolating mean rates of movement between 1430 and 1503, and between 1820 and 1968. In the first case, the 1430–1503 data yield a mean rate of uplift of 120–150 mm a⁻¹, from which the elevation of the marble floor in 1538 is expected to have been between about 4 and 5 m a.s.l. In the second case, the post-1800 data indicate a mean rate of subsidence between 1820 and 1968 of 14 ± 3 mm a⁻¹ (Dvorak & Mastrolorenzo 1991). Extrapolating this rate backwards to 1538 yields an elevation of the marble floor of 4 ± 1 m a.s.l. The similarity of the results is remarkable, suggesting a preferred elevation of 4–5 m a.s.l.

Patterns of vertical movement at Serapis

Table 1 summarizes the elevation data for Serapis from Morhange *et al.* (1999) and this paper; these data are also shown in Figure 7, together with the compilation by Dvorak &

Mastrolorenzo (1991). The data in Figure 7 suggest three episodes each for sustained subsidence and uplift: (1) subsidence from the second century BC to about 500–600 AD, followed by uplift until about 700–900 AD; (2) subsidence from 700–900 AD until about 1430, followed by uplift until 1538; and (3) subsidence from 1538 until 1969, followed by net uplift between 1969 and 2005.

A remarkable feature of these trends is that the periods of most data (before 600 AD and after 1430) can be linked by linear trends with comparable mean rates of subsidence and mean rates of uplift. Thus, the periods of subsidence during the first and third episodes have mean rates of movement of about 16–20 mm a⁻¹ and 13–18 mm a⁻¹ respectively. Together, these values are consistent with a typical background rate of subsidence of about 17 mm a⁻¹, a value to which the area has been tending since 2002 (F. Pingue, INGV–Vesuvius Observatory, pers. comm. 2005). In comparison, the uplifts for the second and third episodes were an order of magnitude greater, at mean rates of about 120–150 mm a⁻¹, before 1538, and of about 230 mm a⁻¹ between 1969 and 1984 (taking the start and end dates of the two phases of uplift). For the movements since 1969, a lower mean rate of subsidence of about 70 mm a⁻¹ is obtained if 2005 (the time of writing) is taken as an end point. Hence, if the post-1969 movements represent the first stages of

Fig. 7. Revised interpretation of changes in vertical elevation at Serapis since Roman times. (a) New data points are compared with the original trend (dashed line) proposed by Parascandola (1947). The new data (Table 1) are from additional original sources in the literature (*crossed squares*) and from radiocarbon and archaeological measurements by Morhange *et al.* (1999; *filled diamonds*). The post-1538 points (*open circles*) show representative data from Dvorak & Mastrolorenzo (1991). (b) The revised interpretation of vertical movements at Serapis indicates that, between Roman times and 1969, two major uplifts have interrupted a general pattern of subsidence; another episode of major uplift may be currently in progress. The mean rates used here are 150 mm a⁻¹ for uplift and 17 mm a⁻¹ for subsidence. (c) Subtraction of the mean rate of subsidence reveals a step-like pattern of uplift. The two episodes before 1969 produced a permanent uplift of 30 m; the current uplift has increased this amount by 3 m (Fig. 8). The simplest interpretation is that permanent uplift has been caused by episodes of magma intrusion (Fig. 9), with each episode interrupting the background rate of subsidence. Notice how the adjusted (permanent) uplift per episode in (c) is greater than the directly observed value in (b), which does not account for the natural subsidence at 17 mm a⁻¹.

GROUND DEFORMATION AT CAMPI FLEGREI, ITALY

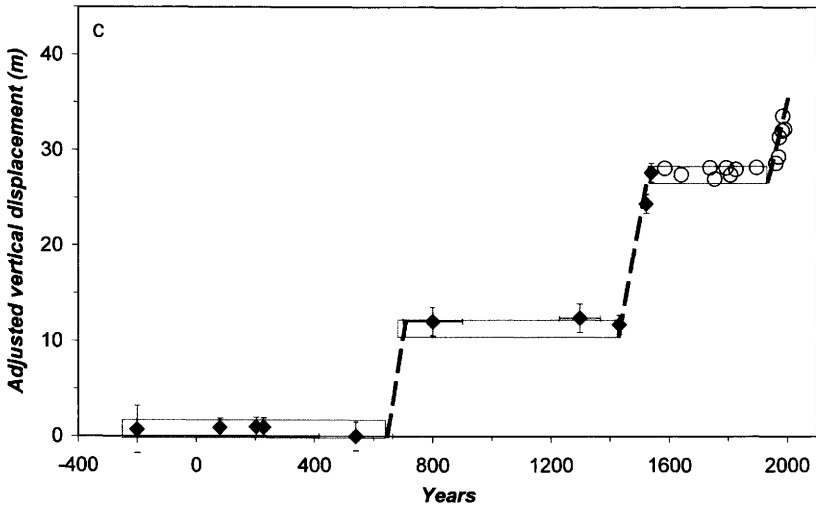
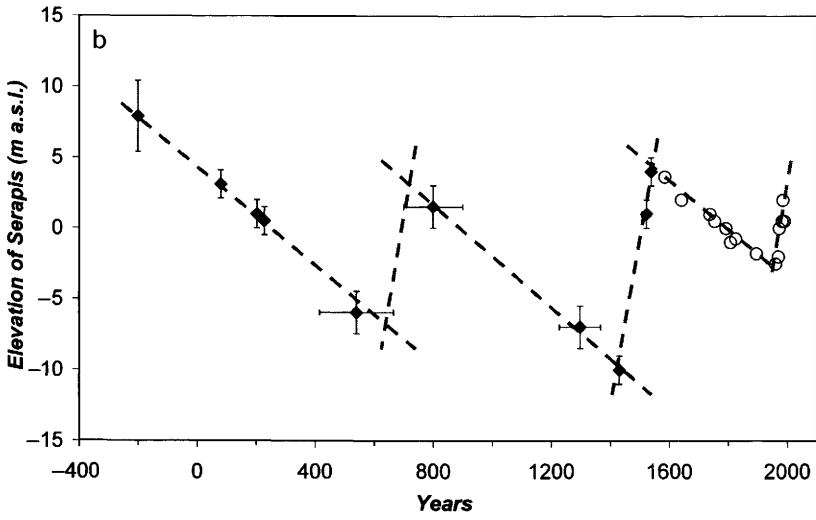
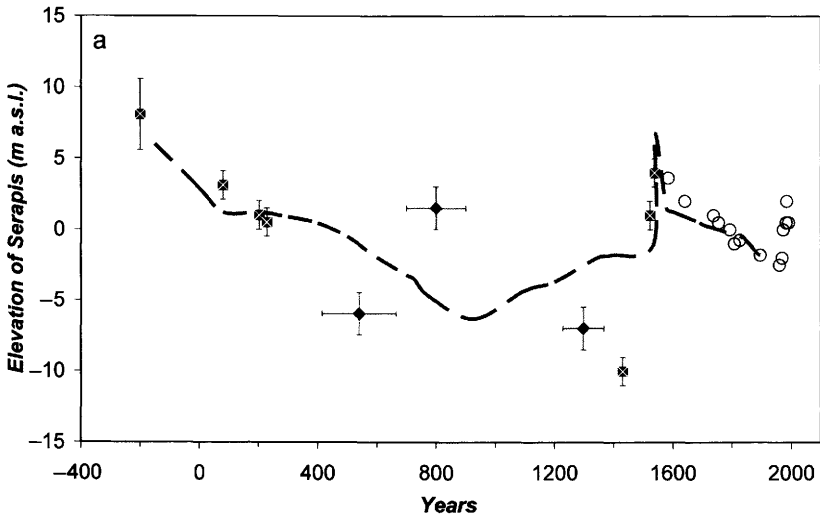

a major episode of uplift, it is plausible that the average rate in the long term will be similar to that before 1538. Accordingly, it is inferred that sustained uplift can occur at mean rates of about 120–150 mm a⁻¹.

The combined mean rates of subsidence and of uplift are consistent with the few data points available for uplift and subsidence during the first and second episodes respectively. The inferred trends are shown in Figure 7, applying mean rates of subsidence and uplift of 17 mm a⁻¹ and 150 mm a⁻¹ respectively. Although the trends between 750 and 1430 are not well constrained, they have the value of simplicity by assuming that their behaviour lies within the ranges provided by the better-constrained trends.

Magmatic intrusions beneath Campi Flegrei

The observation that vertical movements at Serapis have been dominated by subsidence at similar mean rates suggests that such behaviour represents a typical background state (possibly as a result of compaction in the crust or deeper magmatic system following formation of the NYT; e.g. Dvorak & Mastrolorenzo 1991), which occasionally has been punctuated by shorter, but much faster, intervals of uplift. To investigate the nature of the uplifts, therefore, the background rate of subsidence must first be subtracted from the observed trends; this procedure contrasts with previous analyses, for which it has been implicitly assumed that background equilibrium corresponds to no movement.

The results show that the first two uplifts each raised the Serapis by some 15–17 m (Fig. 7), almost ten times greater than the individual episodes of uplift witnessed since 1969 (Fig. 8). Moreover, these displacements are permanent; they appear otherwise only when the background rate of subsidence is ignored. Interpretations of unrest since 1969 suggest that recent deformation has been controlled by a small magma reservoir at a depth of 3–4 km, supplemented by pressure changes in disturbed aquifers at shallower levels (De Natale *et al.* 1991, 2001, 2006 (this volume, pp. 25–45); Gaeta *et al.* 1998); of these mechanisms, magmatic intrusion yields a permanent deformation, whereas the flow of water through disturbed aquifers is expected to yield an uplift followed by a decaying rate of subsidence until the geothermal system has returned to equilibrium (Gaeta *et al.* 1998). Such a decay may indeed be evident in the minor subsidence of Campi Flegrei since 1984. Thus, as seen in Figure 8, following an initial adjusted uplift of

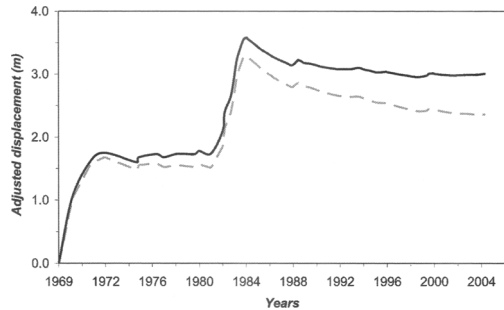

Fig. 8. Adjusted vertical displacement at Serapis between 1969 and 2005 (*solid curve*), after subtracting a background rate of subsidence of 17 mm a⁻¹ (Fig. 7) from the measured deformation (*dashed curve*; Fig. 3). The adjusted curve indicates that no significant movements occurred between 1972 and 1984, and that, by about 2000, the 1982–1984 uplift (of 1.8 m) had decayed by about 0.5 m to a new equilibrium level. The permanent deformation is consistent with magma intrusion from the start of uplift (see also De Natale *et al.* (2006: this volume pp. 25–45)), whereas the 0.5 m decay may reflect the dissipation of fluids from disturbed aquifers.

1.8 m between 1982 and 1984, Pozzuoli subsided by about 0.5 m at a decreasing rate between 1984 and the early 2000s, when the observed rate of subsidence returned to background values. The simplest explanation is that intrusion caused about 1.3 m of permanent displacement, whereas the disturbance of aquifers induced a further 0.6 m of uplift that has since dissipated following fluid migration through the crust.

Assuming a magmatic control, the permanent 1982–1984 displacement can be attributed to the injection of some 10×10^7 m³ of magma into the small reservoir (following Berrino *et al.* (1984) and Dvorak & Mastrolorenzo (1991)). If similar conditions have prevailed since Roman times, therefore, the total permanent uplift of about 33 m indicates that some 1.85 km³ of magma has been intruded at shallow depth. Of this amount, only about 1% has been erupted (during the formation of Monte Nuovo in 1538).

An immediate implication is that, since at least Roman times, magmatic activity at Campi Flegrei has been dominated by intrusion, rather than eruption. Given that similar conditions may have operated during uplift of the Starza terrace (5345 BP) and before the onset of the last major cluster of eruptions (4800–3800 a BP), it is conceivable that Campi Flegrei is again heading towards a period of eruptive activity; in other words, the eruption of Monte Nuovo may be the

first of a new cluster of events over the coming millennia.

Also consistent with a possible return to eruptive activity is that the mean rate of uplift since 1969 has been comparable to the mean rates inferred for the two previous episodes of uplift since Roman times (Fig. 7). Even though the first of these, in the Middle Ages, did not culminate in eruption, the fact that the second ended with the formation of Monte Nuovo in 1538 suggests that conditions in Campi Flegrei are moving progressively towards a greater likelihood of eruption, possibly related to the increase in cumulative crustal stretching. Alternatively, the potential for eruption may increase during each phase of uplift, so that the lack of historical eruptions may simply be the product of statistical criteria, themselves controlled by variations in crustal and magmatic conditions.

The magmatic system feeding Campi Flegrei

A remarkable feature of the adjusted elevation changes (Fig. 7) is that both episodes of major uplift came to rest after similar total amounts of movement. Such a similarity may reflect a fundamental constraint on the behaviour of the magmatic feeding system. Limiting constraints might be imposed by the reservoir receiving the magma, or by the rate at which magma is supplied from deeper levels. The first constraint is unlikely, because each episode of intrusion stretches the crust, so bringing it closer to the critical strain for bulk failure and the formation of a pathway from the reservoir to the surface (Kilburn & Sammonds 2005). Accordingly, the limit to the permanent displacements of 15–17 m must be linked to the volume of magma available for intrusion. This volume, in turn, must be related to how magma is able to migrate upwards from depth.

One possible model is shown in Figure 9. It identifies at least two reservoirs, the shallower of which lies some 3–4 km below the surface (Berrino *et al.* 1984; De Natale *et al.* 2001). The deeper reservoir is supplied with magma until it is able to break the overlying crust. This condition occurs when the reservoir has accumulated an additional volume of magma of about 1 km³. Upon crustal failure, the additional volume escapes as a series of small batches, at a rate faster than the arrival of new magma from depth. The deeper reservoir returns to a pressure equilibrium until another cubic kilometre of new material has accumulated for the cycle to be repeated. The periods of magma accumulation and escape would thus correspond to the

episodes of insignificant adjusted surface deformation (i.e., subsidence at background rates) and of major uplift (Fig. 7).

For such a model to be plausible, the deeper reservoir (1) must be large enough to accommodate about 1 km³ of magma before its overpressure breaks the crust, and (2) must be sufficiently deep so as to not induce significant ground deformation during episodes of magma accumulation. First-order estimates of reservoir volume and depth can be obtained by assuming that the deforming crust behaves elastically, and that, for magma to escape through new fractures, overpressures in the reservoir must reach *c.* 20–40 MPa (to overcome the crust's tensile strength and to open the fractures wide enough for magma to squeeze upwards; Blake 1984; Gudmundsson 1986; Rubin 1995; Jellinek & DePaolo 2003). In this case, the volumetric strain ($\Delta V/V$) due to the accumulation of magma, of volume ΔV , into a reservoir of initial volume V can be approximated by:

$$\Delta V/V \approx \Delta P/K \quad (1)$$

where ΔP is the overpressure and K is the crust's bulk modulus. For $\Delta V = 1$ km³, ΔP between 20 and 40 MPa, and $K = 20$ GPa (Jaeger 1969), eq. (1) gives a volume for the deep reservoir ($\approx K\Delta V/\Delta P$) on the order of several hundred cubic kilometres, which could be accommodated by a disc-shaped reservoir some 6–10 km in radius and 1–2 km thick. The depth, f , of the reservoir can be estimated by assuming a maximum vertical ground deformation, Δh_m , of less than 1 m during the accumulation of ΔV of magma, and applying Mogi's model for elastic deformation (Mogi 1958):

$$\Delta h_m/f = (15/16\pi) (V/f^3) (\Delta P/K) \quad (2)$$

(although designed for a spherical source, the Mogi model yields results for vertical deformation of the same order as those for a disc-shaped source (approximated to a penny-shaped crack) at the same depth; Fialko *et al.* 2001). For Δh_m of less than 1 m, eq. (2) indicates depths of 8–15 km or more for reservoir volumes of 200–800 km³. Although geophysical surveys have yet to explore to depths greater than about 8 km beneath Campi Flegrei, extensive sills have been inferred to occur beneath Vesuvius, about 30 km to the ESE, at depths of 12–15 km and, possibly, also to 35 km (Zollo *et al.* 1996; De Natale *et al.* 2001). It is therefore plausible that, in addition to a reservoir at depths of 3–4 km, Campi Flegrei is underlain at depths greater than 8 km by a zone of magma accumulation with a volume of

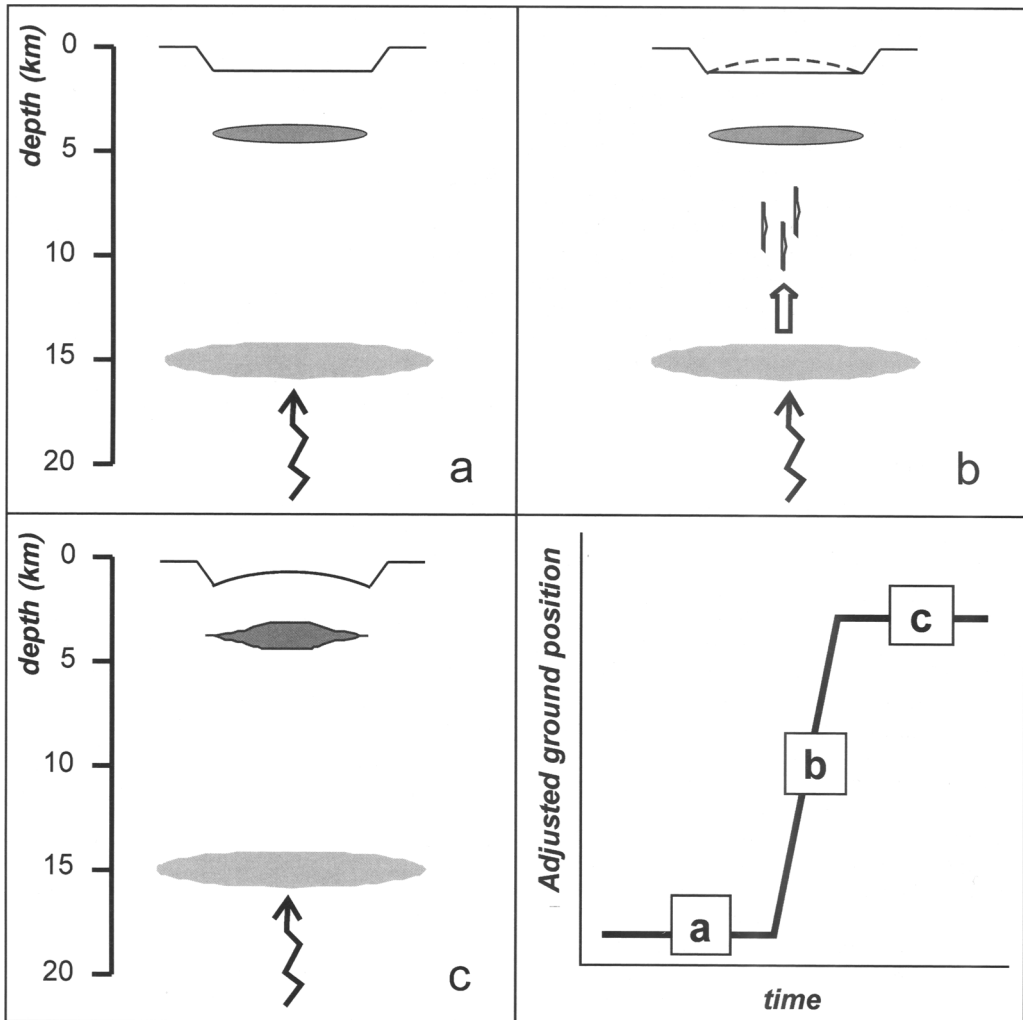

Fig. 9. The patterns of vertical deformation since Roman times are consistent with a two-reservoir system beneath Campi Flegrei. Magma is fed persistently into the lower reservoir (a) until it has accumulated an excess volume ΔV sufficient to cause the overlying crust to stretch and break. The excess volume escapes as a series of magma batches (b) that intrude into the upper reservoir (c). The rate of escape is faster than the rate of magma supply from depth, so that the lower reservoir returns to equilibrium until another excess volume ΔV has accumulated and the cycle is repeated. Periods of magma accumulation in the lower reservoir do not induce significant surface deformation, whereas those of magma ascent generate significant, and permanent, surface uplift (lower right; compare with Fig. 7c). The implication is that, since at least Roman times, Campi Flegrei has been subject to major magma intrusion, even though accompanied by only a modest eruption in 1538.

hundreds of cubic kilometres; indeed, it is interesting to speculate on the possible role of such a body on caldera formation.

Future eruptions in Campi Flegrei

Deformation since 1969 suggests that Campi Flegrei is currently undergoing an episode of

major, intermittent uplift. By analogy with the uplifts in the Middle Ages and before 1538 (Fig. 7) the episode may continue until the vertical displacement has achieved a total adjusted value (after subtracting the background rate of subsidence) of some 15–17 m, that is, some 12–14 m in addition to its displacement since 1969 (Fig. 8). If the adjusted mean rate

of uplift remains similar to that for previous episodes (150 mm a^{-1} ; Fig. 7), the current episode can be expected to continue for another 80–90 years. Hence, because increased crustal displacement favours the possibility of eruption, the twenty-first century is likely to remain a period of elevated volcanic threat in Campi Flegrei, so heralding a return to a potential pre-eruptive state that has not been observed since 1538. Moreover, given that the present interpretation attributes the 15–17 m displacement to the intrusion of some 1 km^3 of magma, the size of a future eruption may well be greater than the $20 \times 10^6 \text{ m}^3$ expelled during the 1538 event.

Conclusions

Morhange *et al.* (1999) presented the first direct evidence that Campi Flegrei may have undergone two episodes of major uplift between Roman times and 1538. Combining their data with new evidence from historical documents, this study argues that the patterns of movement at Serapis, in Pozzuoli, are consistent with the uplift occurring at a mean rate of 150 mm a^{-1} , against a background rate of subsidence of about 17 mm a^{-1} . After the background rate has been removed, a permanent uplift of some 33 m since Roman times (until 2005) can be identified, attributable to the intrusion of 1.85 km^3 of magma; only 1% of this amount has been erupted. The implied mean rate of magma injection of 1–2 km^3 per thousand years is comparable to values inferred for other calderas that erupt evolved magmas (Jellinek & DePaolo 2003). The deformation behaviour can be interpreted in terms of the intermittent ascent of magma between a reservoir of *c.* 10^2 – 10^3 km^3 at depths of 8–15 km or greater, to a much smaller, shallower system at depths of about 3–4 km (Fig. 9). Observations since 1969 further suggest that the caldera is undergoing another episode of major uplift. Should the current pattern of deformation follow previous trends, uplift is expected to continue for another 80–90 years, during which time Campi Flegrei will be characterized by an elevated possibility of eruption.

We thank colleagues at the INGV–Vesuvius Observatory for their help in acquiring modern deformation data for Campi Flegrei. As this article went to press, Morhange *et al.* (2006) presented a further discussion of historical movements in Campi Flegrei, suggesting that the two episodes of major uplift and subsidence between Roman times and 1538 may have been controlled by disturbances in crustal aquifers. Their

analysis assumes that movements in the caldera have occurred against a static background state, unlike the subsiding background rate assumed here. As a result, they require the dissipation of fluids to account for subsidence after each episode of major uplift.

References

- BABBAGE, C. 1847. *Observation on the Temple of Serapis at Pozzuoli near Naples*. Richard & J. E. Taylor, London.
- BERRINO, G., CORRADO, G., LUONGO, G. & TORO, B. 1984. Ground deformation and gravity changes accompanying the 1982 Pozzuoli uplift. *Bulletin Volcanologique*, **47**(2), 187–200.
- BLAKE, S. 1984. Volatile oversaturation during the evolution of silicic magma chambers as an eruption trigger. *Journal of Geophysical Research*, **89**, 8237–8244.
- BREISLAK, S. 1792. *Essais Mineralogiques sur le Solfatare de Pouzzole, Part 3, Observations sur l'Exterieur du Cratere de la Solfatare*. Giaccio, Naples, 170–177.
- CASSIGNOL, C. & GILLOT, P. Y. 1982. Range and effectiveness of unspiked potassium–argon dating: experimental groundwork and applications. In: ODIN, G. S. & WILL, J. (eds) *Numerical Dating in Stratigraphy*. John Wiley & Sons, 160–179.
- CINQUE, A., ROLANDI, G. & ZAMPARELLI, V. 1985. L'Estensione dei depositi marini olocenici nei Campi Flegrei in Relazione alla vulcano-tettonica. *Bollettino della Società Geologia Italiana*, **104**, 327–348.
- D'ANTONIO, M., CIVETTA, L., *ET AL.* 1999. The present state of the magmatic system of the Campi Flegrei caldera based on a reconstruction of its behavior in the past 12 ka. *Journal of Volcanology and Geothermal Research*, **91**, 247–268.
- DEINO, A. L., ORSI, G., DE VITA, S. & PIOCHI, M. 2004. The age of the Neapolitan Yellow Tuff caldera-forming eruption (Campi Flegrei caldera – Italy) assessed by $^{40}\text{Ar}/^{39}\text{Ar}$ dating method. *Journal of Volcanology and Geothermal Research*, **133**, 157–170.
- DE JORIO, A. 1820. *Ricerche sul Tempio de Serapide*. Monumenti inediti di Antichità e Belle Arti, Naples.
- DELLA ROCCA, A. 1985. *Il bradisismo Flegereo e la Nascita del Monte Nuovo nel 1538*. Loffredo, Naples.
- DE LORENZO, G. 1904. L'attività vulcanica nei Campi Flegrei. *Rendiconti Accademia Scienze Fisiche e Matematiche, Serie III, Napoli*, **10**, 204–221.
- DE NATALE, G., TROISE, C., PINGUE, F., DE GORI, P. & CHIARABBA, C. 2001. Structure and dynamics of the Somma–Vesuvius volcanic complex. *Mineralogy and Petrology*, **73**, 5–22.
- DE NATALE, G., TROISE, C., PINGUE, F., MASTROLORENZO, G., PAPPALARDO, L., BATTAGLIA, M. & BOSCHI, E. 2006. The Campi Flegrei caldera: unrest mechanisms and hazards. *Geological Society London, Special Publications*, **269**, 25–45.

- DI BONITO, R. & GIAMMINELLI, R. 1992. *Le Terme dei Campi Flegrei, Topografia Storica*. Jandi Sapi Editori, Milano-Roma.
- DI GIROLAMO, P., GHIARA, M. R., LIRER, L., MUNNO, R., ROLANDI, G. & STANZIONE, D. 1984. Vulcanologia e petrologia dei Campi Flegrei. *Bolletino della Società Geologia Italiana*, **103**, 349–413.
- DI VITO, M. A., LIRER, L., MASTROLORENZO, G. & ROLANDI, G. 1987. The 1538 Monte Nuovo eruption (Campi Flegrei, Italy). *Bulletin of Volcanology*, **49**, 608–615.
- DI VITO, M. A., ISAIA, R., *ET AL.* 1999. Volcanism and deformation since 12,000 years at the Campi Flegrei caldera (Italy). *Journal of Volcanology and Geothermal Research*, **91**, 221–246.
- DVORAK, J. J. & GASPARI, P. 1991. History of earthquakes and vertical ground movement in Campi Flegrei caldera, Southern Italy: comparison of precursory events to the A.D. 1538 eruption of Monte Nuovo and of activity since 1968. *Journal of Volcanology and Geothermal Research*, **48**, 77–92.
- DVORAK, J. J. & MASTROLORENZO, G. 1991. The mechanisms of recent vertical crustal movements in Campi Flegrei Caldera, southern Italy. *USGS Special Paper*, **263**, 1–47.
- FIALKO, Y., KHAZAN, Y. & SIMONS, M. 2001. Deformation due to a pressurized horizontal circular crack in an elastic half-space, with applications to volcano geodesy. *Geophysical Journal International*, **146**, 181–190.
- FLEMMING, N. C. 1969. Archaeological evidence for eustatic change of sea level and earth movements in the Western Mediterranean during the last 2000 years. *Geological Society of America*, **109**, 1–125.
- FORBES, J. D. 1829. Physical notice in the Bay of Naples; Number 5, on the Temple of Jupiter Serapis at Pozzuoli and the phenomena which it exhibits. *Edinburgh Journal of Science*, **1**, 260–286.
- GAETA, F. S., DE NATALE, G., *ET AL.* 1998. Genesis and evolution of unrest episodes at Campi Flegrei caldera: the role of thermal fluid-dynamical processes in the geothermal system. *Journal of Geophysical Research*, **103**(B9), 20 921–20 933.
- GUDMUNDSSON, A. 1986. Formation of dykes, feeder-dykes, and the intrusion of dykes from magma chambers. *Bulletin of Volcanology*, **47**(3), 537–550.
- GUNTHER, R. T. 1903. Earth-movements in the Bay of Naples. IV. The Phlegraean shore-line. *The Geographical Journal*, **22**, 269–286.
- GUNTHER, R. T. 1904. Changes in the level of the city of Naples. *The Geographical Journal*, **24**, 191–198.
- JAEGER, J. C. 1969. *Elasticity, Fracture and Flow*, Third edn, Chapman & Hall, London.
- JELLINEK, M. A. & DEPAOLO, D. J. 2003. A model for the origin of large silicic magma chambers, precursors of caldera-forming eruptions. *Bulletin of Volcanology*, **65**, 363–381.
- JUDENHERC, S. & ZOLLO, A. 2004. The Bay of Naples (Southern Italy): Constraints on the volcanic structures inferred from a dense seismic survey. *Journal of Geophysical Research*, **109**, B10312, doi:10.1029/2003 JB002876
- KILBURN, C. R. J. & SAMMONDS, P. R. 2005. Maximum warning times for imminent volcanic eruptions. *Geophysical Research Letters*, **32**(24), L24313, doi: 10.1029/2005 GL024184
- LEVI, D. 1969. *Enciclopedia dell'arte antica, Classica e Orientale*. Istituto della Enciclopedia Italiana. Treccani, Rome.
- LIRER, L., LUONGO, G. & SCANDONE, R. 1987. On the volcanological evolution of Campi Flegrei. *Transactions of the American Geophysical Union*, **68**, 226–234.
- LYELL, C. 1872. *Principles of Geology*. John Murray, London, 164–179.
- MAIURI, A. 1937. *Campi Flegrei*. Istituto Poligrafico e Zecca dello Stato, Rome.
- MOGI, K. 1958. Relations between the eruptions of various volcanoes and the deformations of the ground surfaces around them. *Bulletin of the Earthquake Research Institute, University of Tokyo*, **36**, 99–134.
- MORHANGE, C., BOURCIER, M., LABOREL, J., GIALLANELLA, C., GOIRAN, J. P., CRIMACO, L. & VECCHI, L. 1999. New data on historical relative sea level movements in Pozzuoli, Phlaegrean Fields, Southern Italy. *Physics and Chemistry of the Earth (part A)*, **24**, 349–354.
- MORHANGE, C., MARRINER, N., LABOREL, J., TODESCO, M. & OBERLIN, C. 2006. Rapid sea-level movements and noneruptive crustal deformations in the Phlegrean Fields caldera, Italy. *Geology*, **34**, 93–96.
- NICCOLINI, A. 1845. *Descrizione della gran terma puteolana volgarmente detta Tempio di Serapide*. Stamperia Reale, Naples.
- ORSI, G., CIVETTA, L., D'ANTONIO, M., DI GIROLAMO, P. & PIOCHI, M. 1995. Step-filling and development of a three-layer magma chamber: the Neapolitan Yellow Tuff case history. *Journal of Volcanology and Geothermal Research*, **67**, 291–312.
- ORSI, G., CIVETTA, L., *ET AL.* 1999. Short-term ground deformations and seismicity in the resurgent Campi Flegrei caldera (Italy): an example of active block-resurgence in a densely populated area. *Journal of Volcanology and Geothermal Research*, **91**, 415–451.
- PARASCANDOLA, A. 1947. *I Fenomeni Bradisismici del Serapeo di Pozzuoli*. Stabilimento Tipografico G. Genovese, Naples.
- ROLANDI, G., BELLUCCI, F., HEIZLER, M. T., BELKIN, H. E. & DE VIVO, B. 2003. Tectonic controls on the genesis of ignimbrites from the Campanian Volcanic Zone, Southern Italy. *Mineralogy and Petrology*, **79**, 3–31.
- ROSI, M. & SBRANA, A. 1987. *Phlegrean Fields*. Consiglio Nazionale delle Ricerche, Rome.
- ROSI, M., SBRANA, A. & PRINCIPE, C. 1983. The Phlegrean fields: structural evolution, volcanic history and eruptive mechanisms. *Journal of Volcanology and Geothermal Research*, **17**, 273–288.

- RUBIN, A. M. 1995. Getting granite dikes out of the source region. *Journal of Geophysical Research*, **100**(B4), 5911–5929.
- SICARDI, L. 1979. Alcune osservazioni sulle tre fasi storiche del bradisismo puteolano rivelate dal Serapeo di Pozzuoli (Napoli). *Bolletino della Societa dei Naturale in Napoli*, **88**, 27–47.
- ŠIMUNOVIĆ, A. & GRUBELIĆ, I. 1992. Biological and ecological studies of the date shell (*Lithophaga lithophaga* L.) from the eastern Adriatic Sea. *Periodicum Biologorum*, **94**, 187–192.
- TROISE, C., DE NATALE, G. & PINGUE, F. 2004. Non-linear effects in ground deformation at calderas due to the presence of structural discontinuities. *Annals of Geophysics*, **47**(4), 1513–1520.
- ZOLLO, A., GASPARINI, P. ET AL. 1996. Seismic evidence for a low-velocity zone in the upper crust beneath Mount Vesuvius. *Science*, **274**, 592–594.